

*Application Guide to
Neutron Multiplicity Counting*

Los Alamos
NATIONAL LABORATORY

*Los Alamos National Laboratory is operated by the University of California
for the United States Department of Energy under contract W-7405-ENG-36.*

*Edited by Jeff Skiby, Group CIC-1
Prepared by Rita Romero, Group NIS-5*

*This work was supported by the U.S. Department of Energy,
Office of Nonproliferation and National Security, Office of
Safeguards and Security.*

An Affirmative Action/Equal Opportunity Employer

This report was prepared as an account of work sponsored by an agency of the United States Government. Neither The Regents of the University of California, the United States Government nor any agency thereof, nor any of their employees, makes any warranty, express or implied, or assumes any legal liability or responsibility for the accuracy, completeness, or usefulness of any information, apparatus, product, or process disclosed, or represents that its use would not infringe privately owned rights. Reference herein to any specific commercial product, process, or service by trade name, trademark, manufacturer, or otherwise, does not necessarily constitute or imply its endorsement, recommendation, or favoring by The Regents of the University of California, the United States Government, or any agency thereof. The views and opinions of authors expressed herein do not necessarily state or reflect those of The Regents of the University of California, the United States Government, or any agency thereof. Los Alamos National Laboratory strongly supports academic freedom and a researcher's right to publish; as an institution, however, the Laboratory does not endorse the viewpoint of a publication or guarantee its technical correctness.

*Application Guide to
Neutron Multiplicity Counting*

*N. Ensslin
W. C. Harker
M. S. Krick
D. G. Langner
M. M. Pickrell
J. E. Stewart*

TABLE OF CONTENTS

ABSTRACT	1
I. INTRODUCTION	2
A. Purpose of the Application Guide	2
B. Definition of Neutron Multiplicity Counting	3
C. Basic Principles of Neutron Multiplicity Counting	4
D. Historical Reasons for Multiplicity Counting	5
E. Areas of Application for Multiplicity Counting	6
F. Advantages and Disadvantages of Multiplicity Counting	7
II. MULTIPLICITY COUNTER DESIGN PRINCIPLES	8
A. Multiplicity Detector Design Goals	8
B. Calculational Tools	9
C. How Calculations Are Used	11
D. Examples of Figure of Merit Calculations	11
E. Examples of Energy Sensitivity Calculations	13
III. SURVEY OF EXISTING MULTIPLICITY COUNTERS	16
A. Basic Differences between Multiplicity and Conventional Coincidence Counters	16
B. Five-Ring Multiplicity Counter	16
C. Three-Ring Multiplicity Counter	18
D. In-Plant (Pyrochemical) Multiplicity Counter	18
E. Plutonium Scrap Multiplicity Counter	19
F. ARIES Neutron Counter (ARNC)	20
G. FB-Line Multiplicity Counter	21
H. Large Neutron Multiplicity Counters	22
I. Shield Cell Drum Counter	24

J. High-Efficiency Neutron Counter (HENC).....	25
K. Plutonium Residues Multiplicity Counter	27
L. Multiplicity Analysis with Conventional Counters	27
IV. MULTIPLICITY ELECTRONICS	28
A. Overview	28
B. Thermal Neutron Detection and Die-Away Time	28
C. Thermal Neutron Detector Electronics	29
D. Derandomizer Circuit	31
E. The Neutron Pulse Stream and Rossi- α Distribution	31
F. Predelay Circuit.....	33
G. Conventional Shift Register Basics	34
H. Multiplicity Shift Register Basics	37
I. Los Alamos MSR4/Canberra 2150 Multiplicity Shift Register	39
J. Los Alamos PSR/Aquila PSR-B Multiplicity Shift Register.....	39
K. Canberra JSR-14 Multiplicity Shift Register.....	40
L. Los Alamos PATRM List Mode Module	40
V. MULTIPLICITY MATHEMATICS	41
A. Overview	41
B. The Spontaneous Fission Process.....	41
C. Description of (α,n) Reactions	44
D. Definition of Sample Multiplication	47
E. Assumptions in the Equations.....	50
F. Definitions of the Multiplicity Distributions and Moments	51
G. The Measured Foreground and Background Multiplicity Distributions	52
H. Extraction of the Correlated Multiplicity Distributions.....	57
I. The Emitted Fission Multiplicity Distribution.....	58

J. The Detected Multiplicity Distribution	59
K. The Detected and Counted Multiplicity Distribution	59
L. Analytical Definition of Singles, Doubles, and Triples	63
M. Final Solution for Sample Mass, Multiplication, α	64
N. Final Solution for Sample Mass, Detector Efficiency, α	65
VI. MULTIPLICITY COUNTER OPERATING PROCEDURES	66
A. Hardware Installation and Setup	66
B. Overview of the NCC Code	66
C. Software Installation and Setup	67
D. Detector Parameter Setup	67
E. Detector Characterization: Background	68
F. Detector Characterization: Bias	68
G. Detector Characterization: Efficiency	69
H. Detector Characterization: Die-Away Time and Gate Width	69
I. Detector Characterization: Gate Fractions	70
J. Detector Characterization: Deadtime Coefficients	71
K. Detector Characterization: Detectability Limit	72
L. Measurement Control Features	73
M. Multiplicity Calibration Procedure	74
N. Additional Correction Factors	76
O. Assay/Verification Sequence	77
P. Measurement Error Calculation	78
VII. APPLICATIONS AND EXPECTED PERFORMANCE	79
A. Factors That Affect Multiplicity Performance	79
B. Plutonium Metal	81
C. Plutonium Oxide	85

D. Plutonium Scrap	88
E. Plutonium Residues	90
F. Plutonium Waste.....	91
G. Verification of Plutonium Oxide in Excess Weapons Materials	93
H. Mixed Uranium/Plutonium Oxide.....	96
I. Mixed Uranium/Plutonium Inventory Verification in Large Drums.....	97
J. Comments on Inventory Verification by Multiplicity Counting	98
VIII. MULTIPLICITY COUNTER SELECTION AND PROCUREMENT	99
A. Summary of When to Apply Multiplicity Counting	99
B. Sample Selection Criteria.....	100
C. Facility Selection Criteria.....	100
D. Multiplicity Counter Selection Criteria.....	101
E. Commercially Available Multiplicity Equipment.....	102
F. Los Alamos Support Options	103
G. Typical Procurement Costs	104
H. Routine Maintenance Requirements.....	104
ACKNOWLEDGMENTS	105
REFERENCES.....	105

APPLICATION GUIDE TO NEUTRON MULTIPLICITY COUNTING

by

N. Ensslin, W. C. Harker, M. S. Krick, D. G. Langner,
M. M. Pickrell, and J. E. Stewart

Abstract

This document is intended to serve as a comprehensive applications guide to passive neutron multiplicity counting, a new nondestructive assay (NDA) technique developed over the past ten years. The document describes the principles of multiplicity counter design, electronics, and mathematics. Existing counters in Department of Energy (DOE) facilities are surveyed, and their operating requirements and procedures are defined. Current applications to plutonium material types found in DOE facilities are described, and estimates of the expected assay precision and bias are given. Lastly, guidelines for multiplicity counter selection and procurement are summarized. The document also includes a detailed collection of references on passive neutron coincidence and multiplicity publications over the last ten to fifteen years.

I. Introduction

A. Purpose of the Application Guide

During the past ten years, a new nondestructive assay (NDA) technique for plutonium, called passive neutron multiplicity counting, has been developed as an extension of neutron coincidence counting. The new technique has led to the design and fabrication of a new generation of instruments, neutron multiplicity counters, one of which is pictured in Fig. 1.1. The development of new neutron counters has been accompanied by advances in data-processing electronics, analysis algorithms, and data-collection software. Development activities have been funded primarily by the Department of Energy (DOE) Office of Safeguards and Security, Technology Development Branch. Altogether, the new technology has led to significantly better measurement accuracy for plutonium metal, oxide, scrap, and residues.



Fig. 1.1. Photo of the Plutonium Scrap Multiplicity Counter, used for accurate assays of cans of plutonium metal, oxide, mixed oxide, or scrap.

There is extensive and growing literature on neutron multiplicity detector design, electronics, data analysis algorithms, performance, and applications as documented in the Reference Section at the end of this guide. Also, Krick (94) has prepared an Application Note on the Passive Neutron Multiplicity Counter that provides a brief summary of the new technology. However, NDA specialists at a number of DOE facilities have requested a comprehensive

document that pulls together the most important information describing the technique, how it works, and how it can be applied. This application guide, sponsored by the DOE Office of Safeguards and Security, is intended to meet this need.

B. Definition of Neutron Multiplicity Counting

Multiplicity is a word that has, well, a multiplicity of meanings! Recently this word even served as the title for a Hollywood movie, in which multiple copies of the leading actor were cloned. Our use of the word begins in a similar way, with the fact that the important NDA signature for plutonium is the process of spontaneous fission, leading to the nearly simultaneous emission of multiple, indistinguishable neutrons as a byproduct of the fission process.

The number of neutrons emitted in spontaneous fission can vary from zero to six or more. The process is random, or statistical, in nature, and the distribution of the number of emitted neutrons is called the neutron multiplicity distribution by the laboratory researchers who have measured it. The multiplicity distribution for spontaneous fission in ^{240}Pu is illustrated in Fig. 1.2, showing that the probability of emitting no neutrons is about 0.066, the probability of emitting one neutron is about 0.232, the probability of emitting two neutrons is about 0.329, etc.

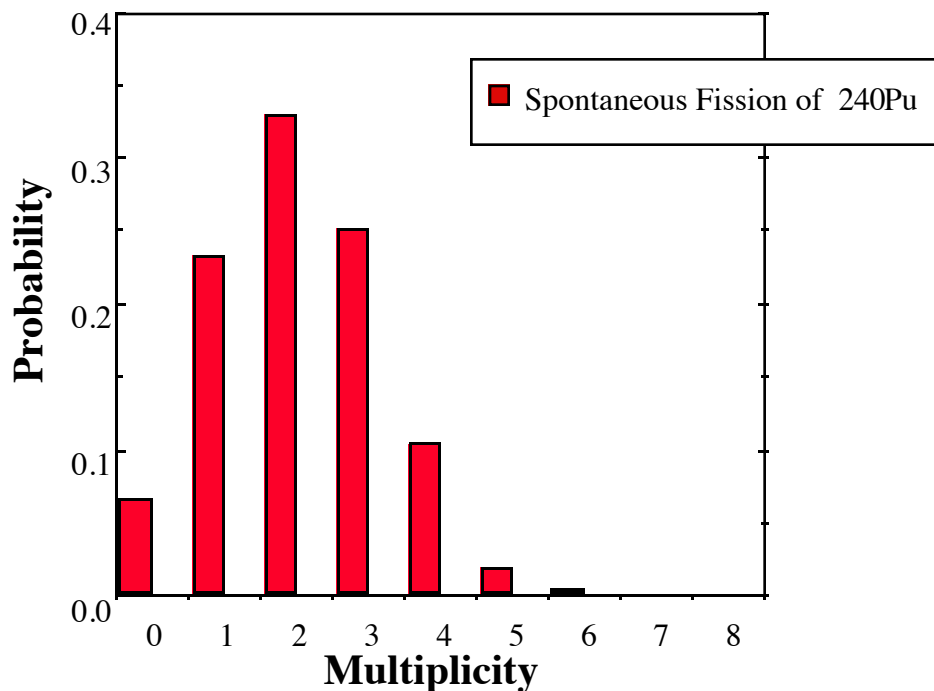

Fig. 1.2. The multiplicity distribution for spontaneous fission in ^{240}Pu .

All passive neutron counting techniques rely on this spontaneous fission process. Total neutron counting simply counts the sum of all the emitted neutrons. Neutron coincidence counting looks for pairs of neutrons that are close together in time, within the coincidence resolving time or “gate width” of the electronics package. However, multiplicity electronics packages are more complex, and sum up separately the number of 0, 1, 2, 3, 4, 5, 6, 7, etc. multiples of neutrons within the coincidence resolving time, as described in Part IV of this guide. Thus they measure a multiplicity distribution of neutrons that are emitted, then detected, and then counted within the gate

width. For this reason, the word multiplicity is specifically associated with the extension of conventional coincidence counting to the collection of higher-order multiples of neutrons. However, we also associate the word multiplicity with a special neutron counter design (Part II) and with the mathematics of the data analysis process (Part V).

In practice, our multiplicity data analysis procedure is not based directly on the observed multiplicity distribution, but on the moments of the distributions, as defined in Part V of this guide. In the language of Part V, the first moment of the neutron multiplicity distribution is the “singles,” or “totals.” The second moment of the neutron multiplicity distribution is the “doubles” or “reals” and the third moment is the “triples.” Neutron multiplicity analysis works with all three of these moments, whereas conventional coincidence counting only uses the singles and doubles. Thus, when we use the word “multiplicity,” we really mean that we will add a third measured parameter, triple coincidences, to the singles and doubles determined by conventional coincidence counting.

C . Basic Principles of Neutron Multiplicity Counting

Neutron coincidence counting is a fast, NDA technique that extracts quite a bit of useful qualitative and quantitative information from the neutrons emitted by plutonium. The coincident neutrons emitted in spontaneous fission provide a strong signature for plutonium. Ideally, this information should provide a unique signature for plutonium, and should also determine the actual grams of ²⁴⁰Pu-effective in the sample, where this quantity is defined as that mass of ²⁴⁰Pu that would give the same double coincidence response as that obtained from all the even isotopes in the actual sample:

$${}^{240}\text{Pu}_{\text{eff}} = 2.52{}^{238}\text{Pu} + {}^{240}\text{Pu} + 1.68{}^{242}\text{Pu} \quad (1-1)$$

Then, high-resolution gamma-ray spectroscopy, mass spectroscopy, or other facility information is used to obtain the isotopic composition of the plutonium, which makes it possible to obtain the total plutonium mass of the sample from the ²⁴⁰Pu-effective mass:

$${}^{\text{Total}}\text{Pu} = {}^{240}\text{Pu}_{\text{eff}} / (2.52f_{238} + f_{240} + 1.68f_{242}) \quad (1-2)$$

where f_{238} , f_{240} , and f_{242} are the fractions of the plutonium isotopes present in the sample.

In practice, the neutron flux emitted by the plutonium sample can be affected by a number of usually unknown, or incompletely known, sample or detector properties. The total list of potentially unknown parameters includes the following:

1. Spontaneous fission rate—the goal of the assay
2. Induced fission, or sample self-multiplication, and its variation across the sample,
3. The (α ,n) reaction rate in the sample,
4. Spatial variation in neutron detection efficiency,
5. Energy spectrum effects on detection efficiency,
6. Neutron capture in the sample, and
7. The neutron die-away time in the detector.

Clearly there are potentially more sample unknowns than conventional coincidence counting can determine. Mathematically speaking, we need N measured parameters to solve for N

unknown sample properties. And conventional coincidence counting provides only two measured parameters, singles and doubles.

The basic principle of neutron multiplicity counting is that a third measured parameter—triples, or the third moment of the measured neutron multiplicity distribution—is obtained. Then it is possible to solve for three unknown sample properties, typically the fission rate (proportional to ^{240}Pu -effective mass), sample self-multiplication, and the (α,n) reaction rate. Then the plutonium mass can be determined without knowing the multiplication or the (α,n) reaction rate in advance. The fourth and fifth unknown parameters, related to neutron detection efficiency, are usually eliminated as an unknown by careful design of the multiplicity counter (see Part II) and calibration (Part VI). Or, for waste drums, we may consider self-multiplication to be known and solve for detection efficiency as the third unknown. The other potential unknowns are usually less important, and are assumed to be small or constant in the math (Part V).

To summarize, multiplicity counting usually determines three measured parameters, singles, doubles, and triples, and solves for three sample properties, ^{240}Pu -effective mass, self-multiplication, and (α,n) reaction rate. Because we are solving three equations for three unknowns, the solution is exact, complete, and self-contained! This has some interesting consequences:

1. For samples that meet the assumptions in the derivations, the assay is bias free and accurate within counting statistical errors.
2. If the sample does not meet the assumptions, the assay will be biased.
3. There is no need for calibration with a series of physical standards, because there is no room in the model for unknown constants.

All of these issues will be explored in detail later in this guide.

D. Historical Reasons for Multiplicity Counting

Historically, the benefit of passive neutron counting has been the great penetrability of neutrons through dense samples. Neutrons are sometimes the only way to rapidly assay large, dense samples. The neutrons can usually measure the entire volume of the item, and they are not easily shielded, with the exception of hydrogenous materials or those containing neutron poisons such as boron. The first neutron assay instruments used the total neutron rate to deduce assay information. However, accurate assays can be obtained only for a very few types of plutonium, as implied by the long list of potential unknowns presented in Section C above.

The next development was neutron coincidence counting. This technique focuses on the spontaneous fission signature and is not affected directly by random (α,n) reactions in the sample matrix. Neutron coincidence counting has had wide application for international safeguards inspections. It has had a more limited application in domestic accountability measurements because large errors can occur if the technique is not applied correctly to impure materials. The fundamental limitation of coincidence counters is that they measure only two parameters: the singles and doubles count rates. For a typical sample, there are at least the first three unknowns listed in Section C: mass m , sample self-multiplication, and the fraction of neutrons from (α,n) reactions. If the sample contains large amounts of neutron moderating or scattering materials, the neutron detection efficiency may be altered and may become another sample-dependent variable.

Thus it is usually not possible to obtain accurate assays of impure samples with conventional coincidence counting. One must either assume that the (α,n) rate is known, and

solve for mass and self-multiplication (Ensslin 85), or assume that self-multiplication is known, and solve for mass and (α,n) rate (Menlove 89). If the assumed information is incorrect, large errors can occur. In fact, for many impure or heterogeneous samples, neither the multiplication nor the (α,n) yield can be known beforehand.

Based on the historical need for better accuracy, the goal of neutron multiplicity analysis is to correctly assay in-plant materials without any prior knowledge of the sample matrix. The availability of a third measured parameter makes this possible for many materials, including moist or impure plutonium oxide, oxidized metal, and some categories of scrap and waste. An additional goal for the design of new neutron counters is to obtain neutron detection efficiencies that are very nearly independent of the sample matrix. A useful neutron multiplicity counter should also retain the assay speed of conventional neutron coincidence counters. At the present time, a practical goal for assay precision is 1% relative standard deviation (RSD) in 1000 s. The limiting factor in meeting this goal is the poor RSD of the triples, or third moment.

E. Areas of Application for Multiplicity Counting

Passive multiplicity counting has safeguards applications in a number of different areas, including:

- a. Improved materials accountability measurements,
- b. Verification measurements,
- c. Confirmatory measurements, and
- d. Excess weapons materials inspections.

Although the historical motivation for developing the technique was improved accountability measurements of impure plutonium, new unexpected applications have arisen in the areas of verification and confirmation because the technique does not require prior knowledge of the sample, or prior calibration with representative physical standards, to obtain a fairly good assay result. For similar reasons, multiplicity counting is coming into use for IAEA inspections of excess weapons materials in DOE facilities, where the inspection goal is verification of materials that may have limited process knowledge or records.

Passive neutron multiplicity counting was developed to assay impure plutonium-bearing materials, but multiplicity counters can be used in place of conventional coincidence counters for all plutonium samples. The additional multiplicity information that the counters can provide will be beneficial primarily on impure plutonium samples such as dirty plutonium oxide, mixed Pu/U oxide, oxidized Pu metal, Pu scrap and waste, Pu process residues, previously unmeasured inventory, and weapons components. There are other material categories where the multiplicity information may not be helpful because of the limited precision of the triple coincidences. These materials include small Pu samples, some Pu-bearing waste, or Pu process residues that are so impure that the high (α,n) reaction rate ruins the precision of the triples signal. For pure Pu metal or oxide, the additional multiplicity information is not needed, and conventional coincidence counting will provide better precision and sufficient accuracy. However, if there are any doubts about the purity of the plutonium, the multiplicity and conventional results can be compared, and the more accurate result can be used. If a multiplicity counter is available, it will always provide faster and better conventional coincidence assays, because of its higher efficiency and flatter

efficiency profile. For the assay of bulk highly-enriched uranium, an active neutron multiplicity counting technique is under development, but is not yet ready for inclusion in this guide.

Additional information on multiplicity counter applications and performance is given in Part VII.

F . Advantages and Disadvantages of Multiplicity Counting

The benefits or advantages of multiplicity counting are summarized in the following list.

1. The measurement accuracy for impure plutonium samples is much greater than for conventional coincidence counting.
2. Information on sample self-multiplication and (α,n) reaction rate is obtained without prior process knowledge.
3. Calibration for many material types does not require representative standards. Thus, the technique can be used for inventory verification without calibration standards, at somewhat reduced accuracy.
4. The measurement time, typically 15–30 min., is still relatively short compared to other techniques.
5. If a multiplicity counter is used for conventional coincidence counting, one can use very short counting times, and expect somewhat better accuracy because of the design of the counter.

The disadvantages of multiplicity counting are summarized in the following list.

1. The cost of a multiplicity counter is higher than the cost of a conventional coincidence counter.
2. The multiplicity counter will require somewhat more floor space and height than a conventional counter of the same cavity size.
3. The measurement time for good precision on triples, typically 15–30 min. or 1000 s, is longer than the 100- to 300-s counting time used for most conventional coincidence assays.
4. For plutonium samples that do not meet the assumptions required by the analysis algorithms, some assay biases still remain. These biases need to be removed by the use of correction factors, special calibration procedures, or by the use of calorimetry to resolve outliers.

Part VIII of this Applications Guide provides a summary of the criteria for when and how to select a multiplicity counter, and where to procure one.

II. Multiplicity Counter Design Principles

A. Multiplicity Detector Design Goals

As mentioned in Part I, the development of the neutron multiplicity technique has led to the parallel development of a new generation of thermal neutron multiplicity counters. Like conventional coincidence counters, multiplicity counters are thermal neutron well counters that use 4-atm ^3He tubes in polyethylene with Amptek amplifiers for neutron detection. However, the design process for these counters represents a significant advance in the state-of-the-art, including the use of calculational tools such as Monte Carlo codes. The overall goal of this design process is to minimize the effects of detector-dependent variables, while taking into account the types of materials the detector will be measuring.

There are at least seven variables that can affect neutron counting for quantitative assay, as summarized in Part I. In terms of detector design, these may be described as follows:

1. spontaneous fission neutron energy spectrum,
2. induced fissions, or self-multiplication, which may be variable across the sample,
3. the (α,n) reaction rate and its neutron energy spectrum,
4. spatial variation in neutron detection efficiency across the counter's sample cavity,
5. potential changes in the neutron energy spectrum leaving the container due to sample matrix materials, such as moderators,
6. neutron capture in the sample, and
7. the neutron die-away time in the detector.

In terms of these variables, the specific goals for multiplicity counter design may be described as follows:

1. Maximize the neutron detection efficiency to increase the detected triple coincidence count rate, which is proportional to the third power of the detection efficiency. A typical design goal is to achieve an efficiency in the range of 40% to 60%. This goal will keep the required assay time for multiplicity counting from becoming too long to meet facility throughput requirements. A desirable result, which can usually be obtained in practice, is 1% RSD in 15–30 min.
2. Minimize deadtime losses in the counting electronics by substantially increasing the number of Amptek preamp/discriminators circuits. Multiplicity counters usually have 20 or more Amptek amplifiers, compared to six in most conventional counters. This is important because the triples rate is much more sensitive to electronic deadtime than the doubles and singles rates.
3. Minimize the detector die-away time, to decrease the background of accidental coincidences, and thereby improve the “signal-to-noise” ratio for triples.
4. Minimize the effects of sample placement in the cavity, or variable plutonium distribution within the sample container, by making the radial and axial efficiency profile of the sample cavity as flat as possible.

5. Minimize the effects of variations in the sample's emitted neutron energy spectrum due to (α,n) reactions or sample moderating materials. The multiplicity analysis equations are derived on the assumption that all neutrons are detected with the same efficiency. However, the detector efficiency is energy dependent, so multiplicity counters are designed to have the detection efficiency as independent of energy as reasonably possible. This is very important to eliminate detection efficiency as one of the potential unknown parameters in multiplicity assay.
6. Make the size of the assay chamber as large as needed for the containers to be assayed, but minimize the overall size of the counter, in terms of floor space required, or height required in case of installation under a glove box.
7. Minimize the fabrication cost of the multiplicity counter. Sometimes this goal requires sacrificing or compromising one or more of the other goals.

B . Calculational Tools

In the design of multiplicity counters, several calculational methods are used to supplement what has been learned experimentally from past designs of conventional coincidence counters. The calculational tools currently used are MCNP and Figure of Merit codes. After the design and fabrication of the counter is completed, the counter's actual efficiency, die-away time, and efficiency profiles are compared with the design calculations. The results so far have been in excellent agreement, thereby validating the calculational approach (Langner 91a, Langner 95). Several examples of the use of these codes is given in Section D below.

Monte Carlo Neutron-Photon (MCNP) is a three-dimensional Monte Carlo code originally developed for neutron and photon transport calculations in support of modeling activities (Briesmeister 93). The code is used to mockup the entire counter geometry, and neutrons are transported through the counter as they undergo scattering, reflection, absorption, or fission until they are lost from the counter. A variety of final neutron tallies are available, including a specialized version that tallies the first and second moments of the detected and counted neutron multiplicity distribution (Stewart 86). Most recently, a new modification of the MCNP code, called MCNP-REN, has been developed to simulate multiplicity counting without using the point model (Abhold 98). Multiplicity counter design calculations are typically performed to a 1-sigma precision of 0.5% to 1.0%. Figure 2.1 is a schematic used in the Monte Carlo design of the Plutonium Scrap Multiplicity Counter (pictured in Fig. 1.1).

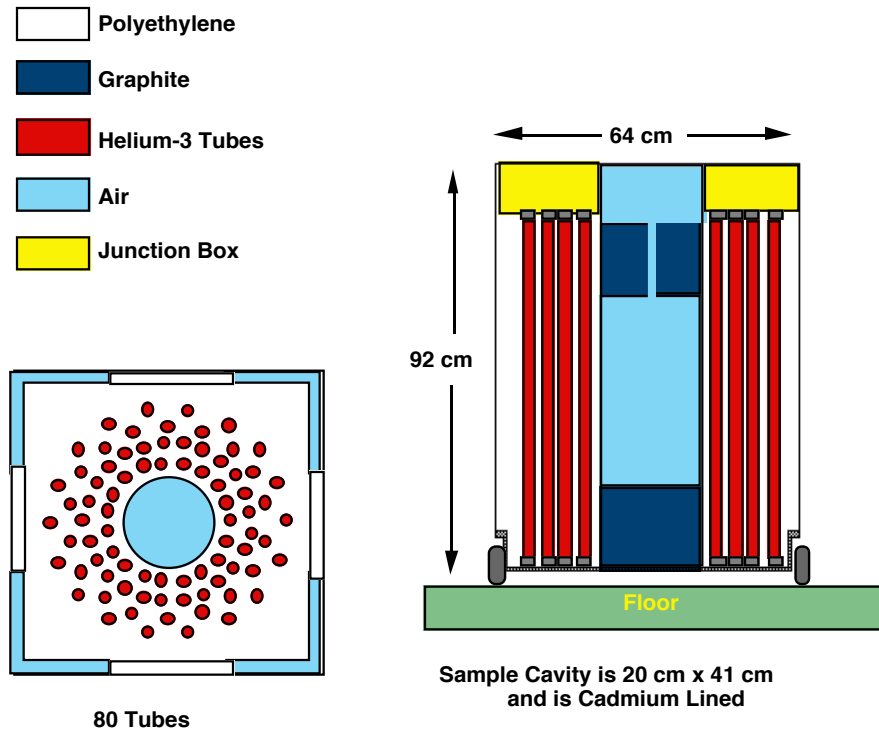

Fig. 2.1. Design schematic for the Plutonium Scrap Multiplicity Counter. In this cross section of the counter, 80 ^3He tubes are arranged around the sample cavity. The space between the tubes is filled with polyethylene. The graphite above and below the sample cavity scatters and reflects neutrons trying to exit the top and bottom of the cavity. The junction box contains the Amptek preamp/ discriminators. The sample cavity is open to the air at atmospheric pressure.

Because the MCNP code provides an estimate for the expected counter efficiency and die-away time, a Figure of Merit code can be used to determine the optimum design target values to achieve the desired measurement precision for a given sample type. One Figure of Merit code developed for multiplicity counting analysis (Ensslin 90a) determines assay variance from the reduced factorial moments of the neutron multiplicity distribution, which may be thought of as single, double, and triple neutron coincidences. The multiplicity distribution does not need to be measured, but is predicted from the detector design parameters obtained from MCNP. Also, the expected values of the sample's mass, self-multiplication, and (α, n) reaction rate, and the preselected count time, electronics package gate width, and pre-delay, are entered into the code. Then the Figure of Merit code can predict the expected single, double, and triple count rates, and determine the expected assay variance. Another more direct approach, developed by Stewart (89), provides a single equation that depends on detector efficiency and die-away time as a Figure of Merit to quickly compare different designs. Either approach can be used as a starting point to determine the design performance needed for a particular sample category.

C. How Calculations Are Used

The above calculational tools can be used in several different ways. One approach is to study the effects of design choices, such as tube placement; the number, size, and pressure of tubes; the tube bank layout; the placement of different neutron moderator or reflector materials; the use of cadmium liners; etc. Important design issues include reducing thermal neutron return to a sample, using end caps to reflect neutrons back into the assay chamber, using different neutron shielding materials to protect personnel and to reduce external neutron backgrounds, and providing a tight-fitting assay chamber with a neutron-symmetric design.

Also, the calculations can be used to predict and analyze design performance. Important criteria include determining the spatial response characteristics of the assay chamber (the neutron detection efficiency as a function of location), energy response characteristics (the neutron detection efficiency as a function of the emitted energy spectrum), sample/detector coupling effects, and criticality safety concerns.

Lastly, calculations can be used in support of research and development activities, such as planning for new counter designs or predicting the required counting time and expected assay precision of upcoming measurement campaigns. Additional schematics for several multiplicity counter designs are given in Part III of the guide. Examples of other applications for the calculations are given in the next two sections.

D. Examples of Figure of Merit Calculations

This section provides examples of the use of Figure of Merit calculations of expected assay precision. Once the sample mass and size range to be measured have been defined, these calculations can be used to define the target efficiency and die-away time needed to obtain a given assay precision in a given counting time. Fig. 2.2 illustrates the expected assay precision or RSD vs ^{240}Pu mass for plutonium oxide samples in a 50% efficient multiplicity counter, for 1000-s counting time. From this figure, one can determine whether or not a 50% efficiency is sufficient to give the needed assay precision over the range of expected sample sizes.

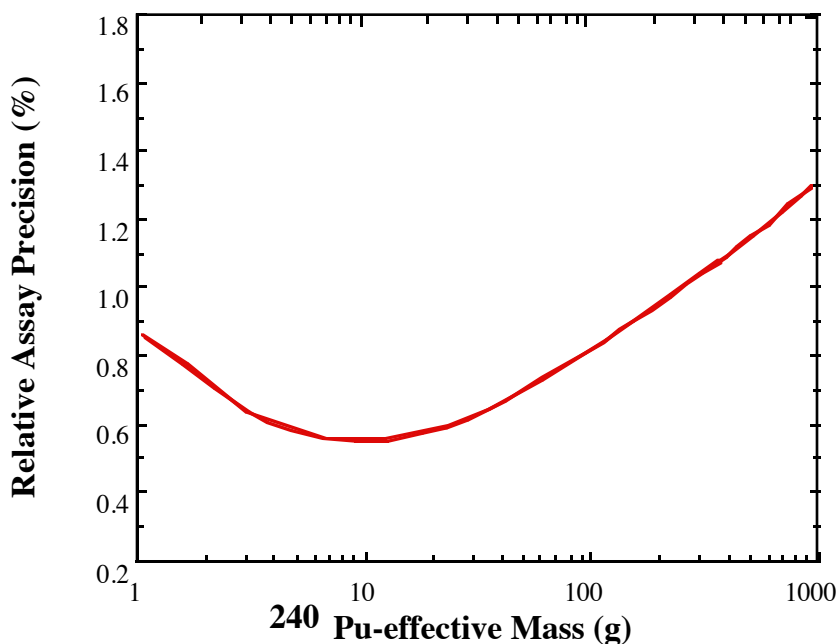

Fig. 2.2. Figure of Merit calculation of expected assay precision (RSD) vs ²⁴⁰Pu-effective mass for plutonium oxide samples in a 50% efficient multiplicity counter, for 1000-s count time.

Fig. 2.3 is a Figure of Merit calculation of expected precision vs ²⁴⁰Pu-effective mass for three values of α (the ratio of (α,n) to spontaneous fission neutrons) for a 57% efficient multiplicity counter, for 1800 s count time. As the ratio of (α,n) neutrons emitted by the sample increases, the assay precision deteriorates rapidly. For impure plutonium samples, the Figure of Merit calculation is the fastest way to determine the efficiency, die-away time, and count time that will be needed to provide a given assay precision.

A third use of Figure of Merit calculations is to compare the expected performance of detector designs with different combinations of efficiency and die-away time. This facilitates the process of design optimization. Additional Figure of Merit calculations are illustrated in Part VII.

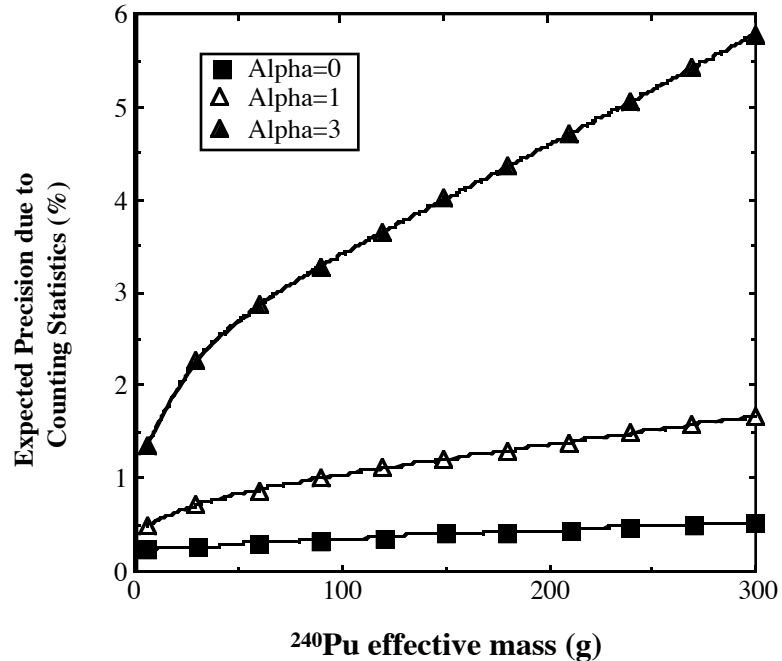

Fig. 2.3. Figure of Merit calculation of expected precision vs ²⁴⁰Pu-effective mass for three values of α (the ratio of (α, n) to spontaneous fission neutrons) for a 57% efficient multiplicity counter, for 1800-s count time.

E. Examples of Energy Sensitivity Calculations

The MCNP code is used to calculate the expected neutron detection efficiency as a function of the emitted neutron energy spectrum to test the “flatness” of the multiplicity counter design. Figure 2.4 illustrates the neutron detection efficiency (relative to the efficiency at 2 MeV) vs neutron energy for the HLNCC-II and the In-Plant Pyrochemical Multiplicity Counter. The HLNCC-II is a conventional coincidence counter with one ring of ³He tubes designed for portable field applications. The Pyrochemical Multiplicity Counter has four rings of ³He tubes and was specifically designed to measure process samples with variable (α, n) yields and variable neutron energies (see Part III, Section D). Clearly it has a much flatter efficiency profile in terms of neutron energy. Figure 2.5 compares the neutron detection efficiency (relative to the efficiency at 2 MeV) vs neutron energy for the In-Plant Pyrochemical Multiplicity Counter and the Plutonium Scrap Multiplicity Counter on an expanded scale. We see that both multiplicity counters have similar profiles, but that the Plutonium Scrap Multiplicity Counter, which has fewer ³He tubes, is not quite as flat as the Pyrochemical Counter.

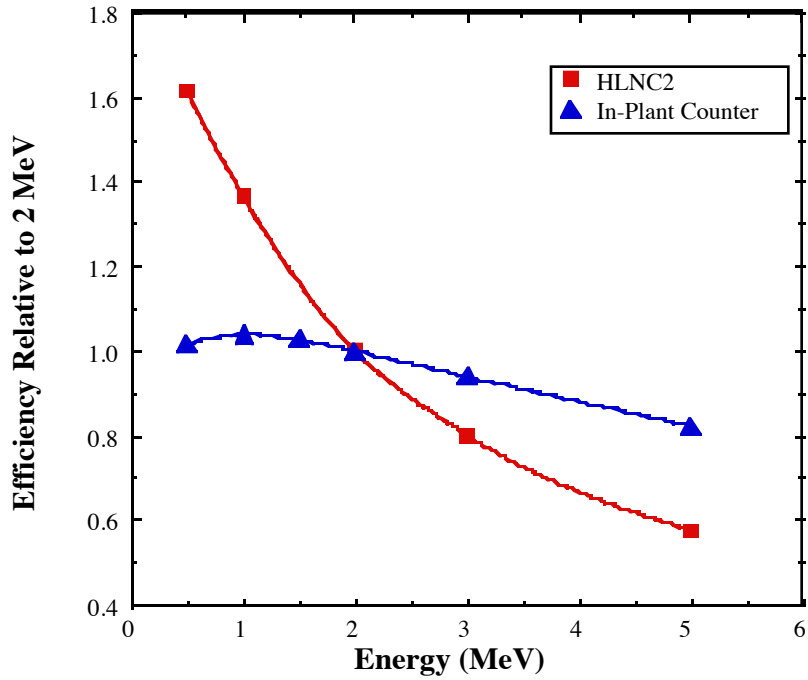

Fig. 2.4. Neutron detection efficiency (relative to the efficiency at 2 MeV) vs neutron energy for the HLNC2 coincidence counter and the Pyrochemical Multiplicity Counter.

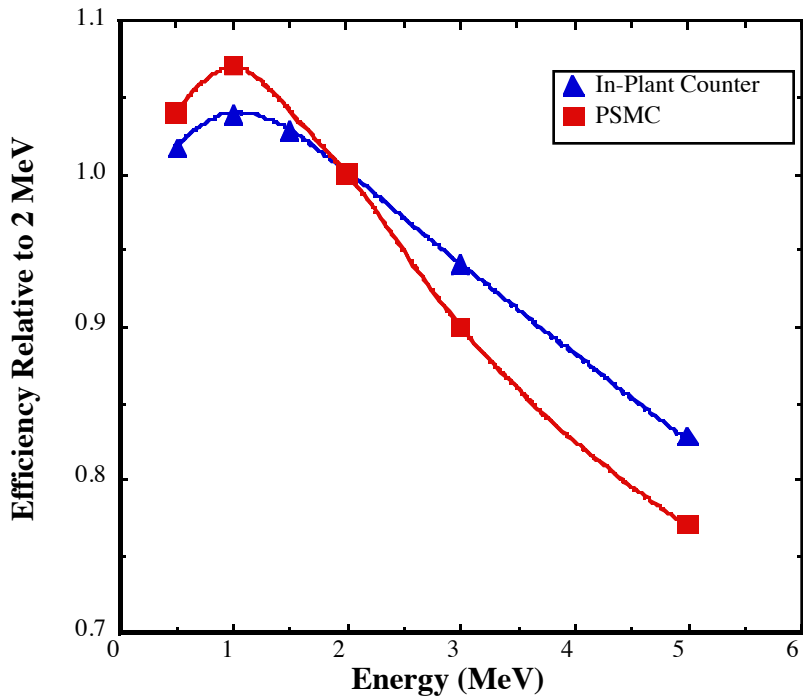

Fig. 2.5. Neutron detection efficiency (relative to the efficiency at 2 MeV) vs neutron energy for the In-Plant Multiplicity Counter and the Plutonium Scrap Multiplicity Counter (PSMC).

Multiplicity counters achieve their flat energy response largely through the use of multiple rings of ^3He tubes placed at different depths in the polyethylene moderator material. Figure 2.6 plots the relative count rate responses for the four tube rings in the In-Plant Pyrochemical Multiplicity Counter as a function of neutron energy. Each ring responds differently, but the sum of all four, as plotted in Figs. 2.4 and 2.5 above, is very nearly constant.

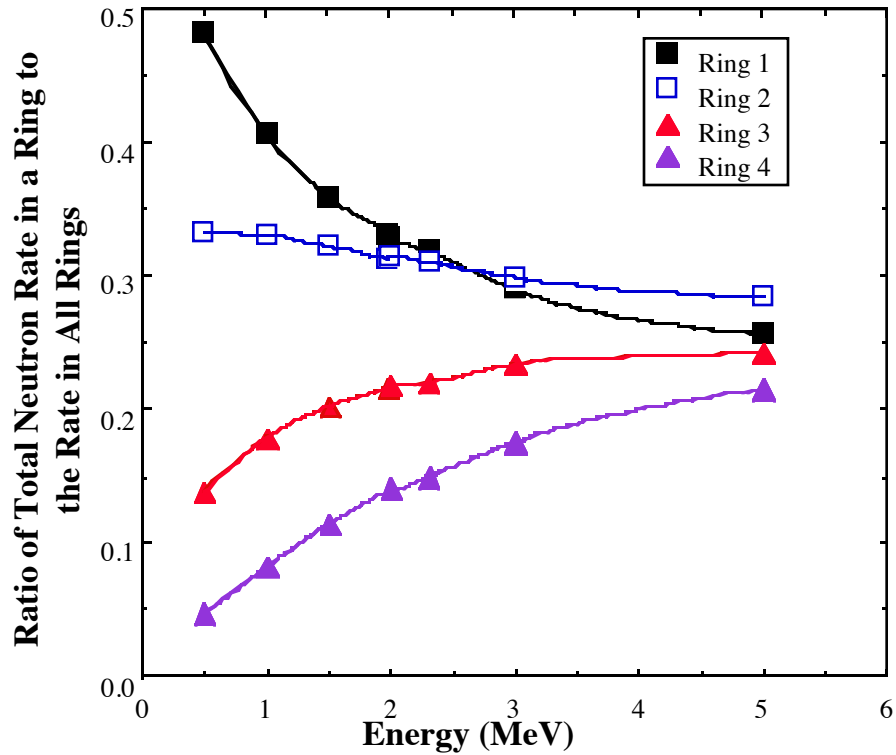

Fig. 2.6. Relative count rate responses for the four tube rings in the Pyrochemical Multiplicity Counter as a function of neutron energy. Ring 1 is the innermost ring, and ring 4 is the outermost ring.

III. Survey of Existing Multiplicity Counters

A. Basic Differences between Multiplicity and Conventional Coincidence Counters

Neutron multiplicity counters are similar in design and construction to neutron coincidence counters. Both are thermal neutron detector systems (rather than fast scintillators) that utilize polyethylene-moderated ^3He proportional counters. Both employ Amptek preamp/discriminators and shift register-based electronics packages, although for multiplicity counting the electronics packages must be designed to collect the multiplicity distribution information, as discussed in Part IV below.

However, multiplicity counters are designed to maximize neutron counting efficiency and minimize neutron die-away time, as described in Part II above. They also have much lower electronic deadtimes, and their detection efficiencies are less dependent on neutron energy. Table 3.1 lists the multiplicity counters that are currently in use in DOE facilities and provides a summary of their most important design features. By way of comparison, conventional coincidence counters typically have one or two rings of ^3He tubes, efficiencies of 18% to 25%, and deadtimes on the order of 200 ns or more. The rest of this part of the Application Guide provides descriptions of the multiplicity counters listed in Table 3.1.

B. Five-Ring Multiplicity Counter

This counter is the first thermal neutron counter designed specifically for multiplicity measurements (Krick 84, Langner 91). It was built with five rings of ^3He tubes to ensure a very high neutron detection efficiency for developing new multiplicity techniques (see Fig. 3.1). However, the ^3He tubes were originally installed in an aluminum moderator assembly to minimize the neutron die-away time. It was also possible to wrap each ^3He tube individually with a removable cadmium liner, and for that reason the counter was called the Dual-Mode Multiplicity Counter. With the cadmium in place, the efficiency was found to be 17%, with a die-away time of 11.8 μs . With the cadmium removed, the efficiency was found to be 53%, with a die-away time of 57 μs .

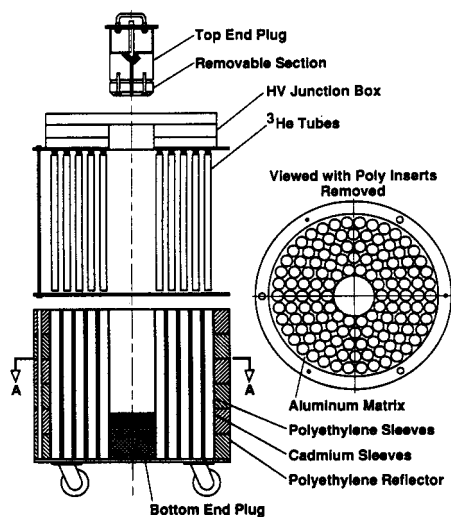

Fig. 3.1. Schematic of the Five-Ring Multiplicity Counter.

Table 3.1. Summary of Current Multiplicity Counters in DOE Facilities

Multiplicity Counter Name	Location	Application	No. of tube rings	No. of ³ He tubes	No. of Amptek preamps	Derandomizer	Deadtime (ns)	Neutron Det. Effic. (%)	Die-Away Time (μs)	Cavity Size
Five-Ring Multiplicity Counter	Los Alamos	Technology Development	5	130	34	Yes	36	53	49	16.5 cm D x 25.4 cm H
Three-Ring Multiplicity Counter	Los Alamos	Technology Development	3	60	12	Yes	83	45	63	20 cm D x 30 cm H
Pyrochemical Multiplicity Counter	Los Alamos	In-plant metals, oxides	4	126	36	No	90	57	47	24 cm D x 38 cm H
Plutonium Scrap Multiplicity Counter	Hanford	Pu Inventory Verification	3 1/2	80	19	No	121	55	47	20 cm D x 41 cm H
ARIES Neutron Counter	Los Alamos	Pu metals and residues	3 1/2	80	20	Yes	60	55	47	20 cm D x 41 cm H
FB-Line Multiplicity Counter	Savannah River	Metal, oxide inventory	4	113	24	Yes	50	58	50	20 cm D x 41 cm H
30-Gallon Multiplicity Counter	Rocky Flats	Excess weapons oxide	3	126	54	Yes	25	42	55	30-Gallon Drum
30-Gallon Multiplicity Counter	Livermore	Inventory verification	3	126	54	Yes	25	42	55	30-Gallon Drum
Shield Cell Waste Drum Counter	Los Alamos	Waste R&D, training	2	89	33	No	260	30	65	55-Gallon Drum
High-Efficiency Neutron Counter	Los Alamos	Waste assay	2	113	16	No	171	32	50	55-Gallon Drum
Plutonium Residues Multiplicity Counter	Rocky Flats	Plutonium salts and residues	3 1/2	73	19	No	111	37	74	30 cm D x 30 cm H

Recently, the Five-Ring counter was rebuilt with polyethylene moderator rather than aluminum to improve the energy response profile for measurement control studies. The efficiency is still 53%, and the neutron die-away time is now 49 μ s. The Five-Ring counter played a very important role in the development of multiplicity counting because it demonstrated that thermal neutron multiplicity counters could provide good assays of plutonium samples in reasonable counting times.

C. Three-Ring Multiplicity Counter

The Three-Ring Multiplicity Counter was originally built as an experimental active well coincidence counter. It was converted from an active counter to a passive counter by removing the polyethylene end plugs that held the AmLi sources and replacing them with shorter graphite end plugs. The counter was also upgraded by replacing the six original preamplifier boards in the high-voltage junction box with 12 Amptek Boards and a derandomizer.

This counter has been used for research and development activities, for training classes in multiplicity counting, and for temporary use in IAEA inspections of excess weapons materials at the Hanford facility (Stewart 96a). However, because this counter is actually a converted conventional coincidence counter, its performance specifications are not as good as those of a counter specifically designed to be a multiplicity counter. The neutron detection efficiency is lower (only 45%), and the spatial and energy response profiles are not as flat. Nevertheless, the counter was able to verify most of the items assayed at Hanford, thereby significantly reducing the number of samples taken for destructive analysis.

D. In-Plant (Pyrochemical) Multiplicity Counter

Based on experience gained with the above research counters, the In-Plant or Pyrochemical Multiplicity Counter was designed to be more suited to in-plant use and to optimize the parameters identified as important for multiplicity assay (Langner 91a, b). The counter was designed in two halves, so that it could be installed around a facility glove-box well. The design schematic is given in Fig. 3.2. The optimum arrangement of ^3He tubes, a 1.59-cm tube spacing, and the best choice for the end plug materials was determined from Monte Carlo design calculations (Langner 90). The result is a very high performance counter with a single-exponential die-away curve. The very flat energy response profile of this counter was illustrated in Fig. 2.4 and 2.5 in Part II, and the energy response of the individual tube rings was illustrated in Fig. 2.6. The spatial response profile is also very flat, as shown in Langner (91a).

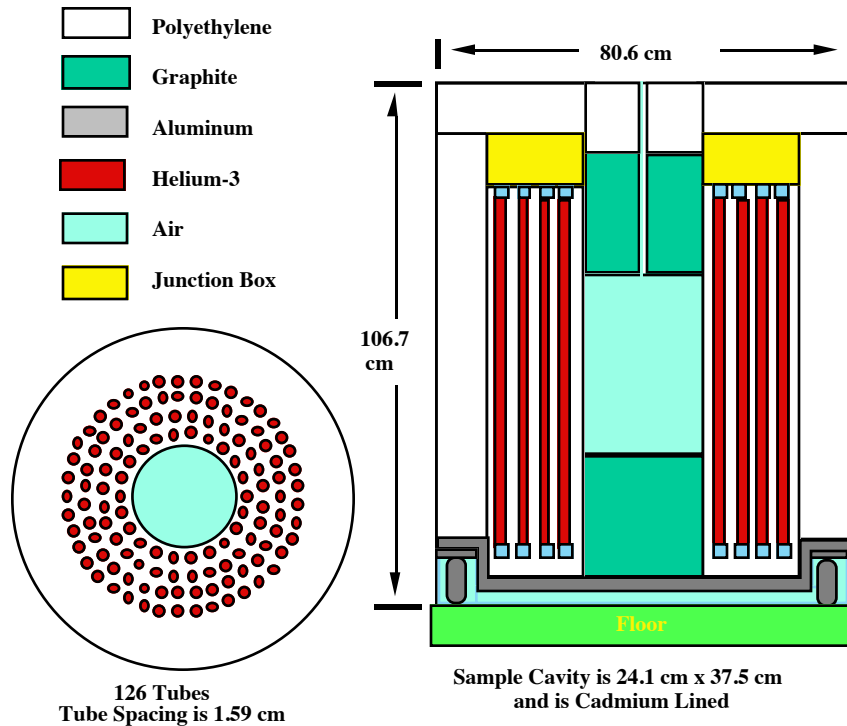

Fig. 3.2. Design schematic for the In-Plant (Pyrochemical) Multiplicity Counter.

The In-Plant Counter has been used in the Los Alamos Plutonium Facility and at the Lawrence Livermore National Laboratory to assay inventory items. At Los Alamos, the counter was used to assay Pu metal, oxide, and high (α, n) reaction electrorefining salts (Krick 92). At Livermore, the counter was used to assay low and high burnup Pu metal and oxide (Langner 93b). These in-plant evaluations established for the first time that the three-parameter multiplicity analysis model (described in Part V below) would yield assay results (described in Part VII below) that were significantly better than those obtained by conventional two-parameter coincidence counting.

E. Plutonium Scrap Multiplicity Counter

The Plutonium Scrap Multiplicity Counter (PSMC) is a high-efficiency multiplicity counter for the measurement of impure plutonium and mixed oxide (MOX) scrap materials in the mass range of a few tens of grams to several kilograms of high-burnup plutonium (Menlove 93). The PSMC was pictured in Fig. 1.1, and a design schematic was given in Fig. 2.1. It was designed to be more compact in size and weight than the In-Plant Multiplicity Counter and to use fewer ^3He tubes. The outer dimensions of the counter are 66 cm by 66 cm by 92 cm high.

MCNP calculations were used to improve the PSMC significantly compared with prior designs. For example, the In-Plant Counter used 126 tubes to obtain an efficiency of 57%, whereas the PSMC uses 80 tubes to get an efficiency of 55%. One way this was achieved was to reduce the number of ^3He tubes in each ring in proportion to the decrease in the thermal neutron flux intensity in the moderator. Thus the last ring of ^3He tubes is only about half filled, and in Table 3-1 the PSMC is described as having 3 1/2 rings of tubes. These design features resulted in slight degradations in the die-away time and energy response. The energy response profiles of the two counters were illustrated in Fig. 2.5.

The PSMC uses 19 Amptek preamp/discriminator circuits. In the inner ring, there are three ^3He tubes per Amptek, and in the outermost ring there are six tubes per Amptek. Figure 3.3 is a photograph of the ^3He tubes, high-voltage junction box, and Amptek indicator lights on the PSMC. The multiplicity deadtime coefficient is 121 ns. The axial efficiency profile is constant to within $\pm 2\%$ over the 41-cm height of the cavity. This makes it easy to place most scrap and MOX containers entirely within the flat portion of this efficiency profile. The first PSMC was fabricated for a MOX facility in Japan. The PSMC is now commercially available through Canberra Industries, Inc.



Fig. 3.3. Photograph of the ^3He tubes and high-voltage junction box partly withdrawn from the Plutonium Scrap Multiplicity Counter.

F. ARIES Neutron Counter (ARNC)

An in-line active/passive neutron counter has been developed for permanent installation in the Los Alamos Plutonium Facility (Sampson 93). The Advanced Recovery and Integrated Extraction System (ARIES) Neutron Counter (ARNC) will provide the ARIES weapons dismantlement project with the capability to handle both plutonium and uranium items. Plutonium assays can be done by passive neutron coincidence counting, passive multiplicity counting, or combined active minus passive coincidence counting. Active assay of uranium will be accomplished using a separate, removable set of end plugs equipped with AmLi neutron interrogation sources. Sample changing or changing of the end plugs from passive to active will be accomplished by a robotic sample-handling system built into the glove box.

The ARIES Neutron Counter will have similar performance to the PSMC, with the same number of ^3He tubes (80) and tube rings. Because the body of the counter needs to split into two

halves for installation around the glove-box well, the counter has 20 rather than 19 Ampteks. Also, a derandomizer circuit is provided, so the multiplicity deadtime is less than for the PSMC.

G. FB-Line Multiplicity Counter

The FB-Line Neutron Multiplicity Counter (FBLNMC) was developed to measure impure plutonium at the Westinghouse Savannah River Site FB-Line Facility (Langner 97c, Langner 98). The FBLNMC can be applied to impure samples that range in mass from a few tens of grams to several kilograms of plutonium; both conventional coincidence counting and multiplicity counting can be used as appropriate. The instrument can measure neutronically thin materials such as oxides and residues using a single calibration. Metal buttons require an additional calibration.

The new FBLNMC was designed to provide all state-of-the-art features in a single compact package. Monte Carlo calculations were used to design the high-efficiency (57%) detector using 113 ^3He tubes in a high-density polyethylene body (see Fig. 3.4). There are several improvements over the earlier PSMC design that are important for the wide variety of materials to be measured at Savannah River. The axial efficiency profile varies by less than $\pm 2\%$ over the height of the cavity, and the radial efficiency variation over a 16-cm diameter can be only 1.5% at the midplane of the sample cavity. A derandomizer circuit (described in Part IV below) reduces the deadtime of the counter by more than a factor of 2 to 50 ns. The overall energy response profile of the counter is extremely good, identical to that of the Pyrochemical Multiplicity Counter (see Fig. 3.5). Also, the individual ring outputs can be read by two auxiliary scalars to diagnose sample anomalies. The ratio of the rates in the inner to outer rings provides a sensitive indication of the mean energy of the neutrons emitted by a sample and is strongly influenced by sample moderator or (α, n) reaction neutrons.

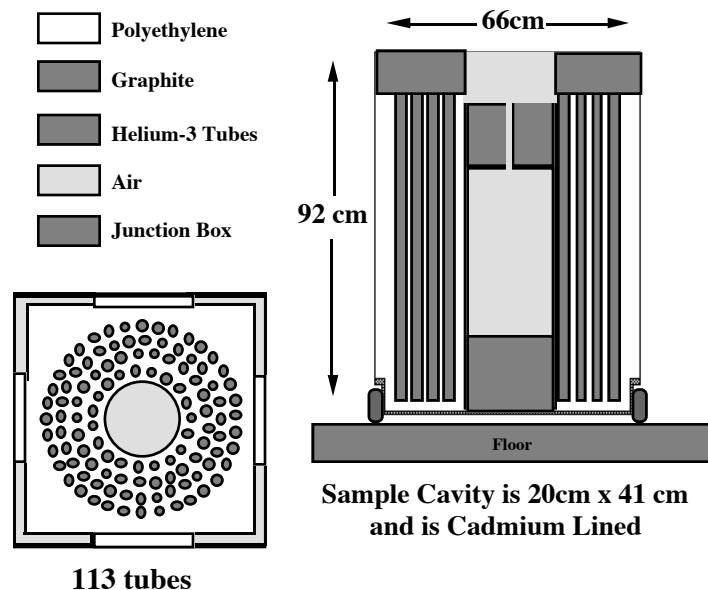

Fig. 3.4. Schematic diagram of the FBLNMC showing the location of the 113 ^3He tubes and the graphite end plugs.

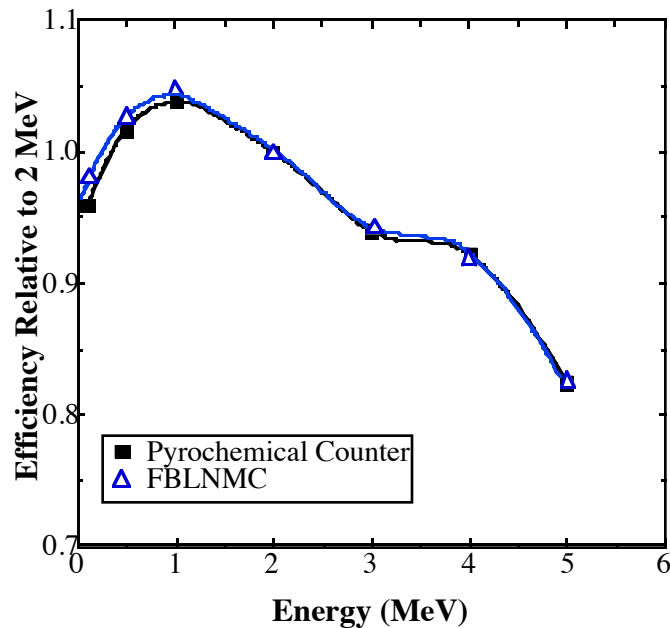

Fig. 3.5. MCNP calculations of the efficiency vs the neutron energy for the FBLNMC and the Pyrochemical Multiplicity Counter.

H. Large Neutron Multiplicity Counters

The Large Neutron Multiplicity Counter (LNMC), or 30-gal. Drum Counter, represents an important extrapolation of neutron multiplicity design concepts to a much larger sample volume (Langner 94). The number of ^3He tube rings was reduced to three to save cost, but aluminum corner reflectors are used to help maintain a good spatial response profile near the corners. To facilitate loading heavy 30-gal. drums or ATR400 long-term storage containers from the side rather than the top, a hexagonal design was used, with the two front sides forming the doors. The mechanical arrangement of the counter and the doors is shown in Fig. 3.6. The counter has an efficiency of 42% and a die-away time of 55 μs , which is sufficient for multiplicity analysis of bulk plutonium materials in the kilogram range (Langner 95). Fifty-four Amptek preamp/discriminators and a derandomizer circuit are used to obtain an extremely low multiplicity deadtime of 25 ns, which is very helpful for assay of such large items.

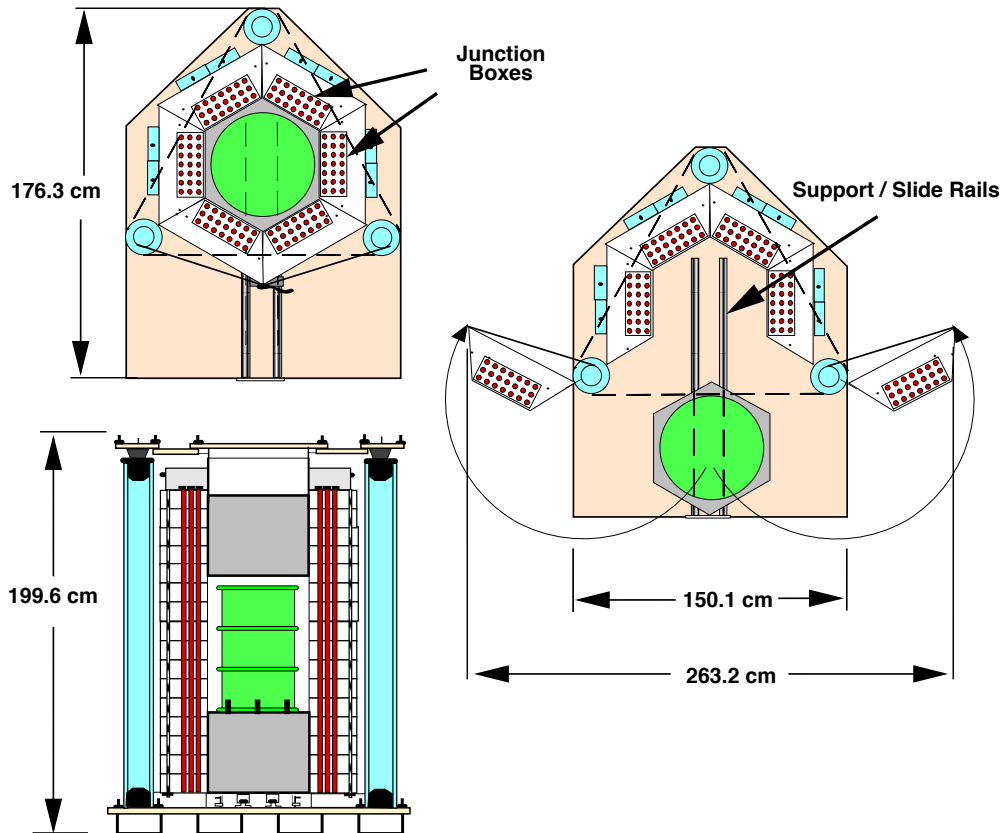

Fig. 3.6. Mechanical schematic for the Large Neutron Multiplicity Counter.

One LNMC is installed at the Rocky Flats Environmental Technology Site (RFETS) where it is used for IAEA inspections of excess weapons materials (see Fig. 3.7). The RFETS materials offered for IAEA inspections consist of two 2-kg Pu oxide cans stacked one above the other in a 10-gal. drum (Langner 96b). On such samples, the average neutron counting precision is about 2.6% in 30-min counting times, except for samples with high (α,n) reaction rates, where the precision ranges from 3% to 12%. For over 100 drums measured so far during the Physical Inventory Verification exercises, the LNMC was able to verify all to within 3 standard deviations or better, except for one drum with an unusually high neutron emission rate (Langner 97b).



Fig. 3.7. The RFETS Large Neutron Multiplicity Counter.

Another LNMC is installed at the Livermore Nuclear Materials Facility, where it is used for inventory verification. The efficiency and die-away time of this counter are nearly identical to the one at RFETS, with only slight differences due to variations in mechanical fabrication and assembly (Langner 95). In addition, the Livermore counter is equipped with active inserts that fit into the top and bottom of the assay chamber. These can be used for active coincidence or active multiplicity counting of uranium items.

I. Shield Cell Drum Counter

Neutron coincidence counters large enough to assay plutonium waste in 55-gal. drums usually have detection efficiencies in the range of 15% to 18%. Also, waste drums may contain only a few grams of plutonium, rather than bulk quantities. Both of these considerations suggest that the triples count rate in waste might be too low to obtain multiplicity assays in reasonable counting times. However, because multiplicity analysis of waste offer several potential benefits for safeguards, new waste drum counters with substantially higher neutron detection efficiencies have recently been developed.

One of these is the Shield Cell Drum Counter, which is built into a shield cell at the Los Alamos safeguards laboratory (Pickrell 96). Figure 3.8 is an overview of this multiple-purpose counter and its movable entry door. The counter is built next to the 5-ft-thick wall of the shield cell, so that the wall can be used to store californium neutron sources. The assay system can serve as a californium shuffler for active neutron assay, and as a passive neutron multiplicity counter with segmented add-a-source matrix correction capability.



Fig. 3.8. The Shield Cell Drum Neutron Counter, with multiplicity, shuffler, and add-a-source capability.

The Shield Cell Drum Counter contains a single assay chamber for 55-gal. drums. The drum to be assayed is placed in the chamber where it is surrounded by neutron detectors on all four sides and on the top and bottom. This $4\text{-}\pi$ geometry provides good detection efficiency, shields against room background, and provides a detector response that is independent of the actual location of the plutonium within the drum, to about 5% or 10%. The drum is also rotated for maximum coverage and interrogation uniformity. There are 89 ^3He tubes positioned in two rows in the six banks, and the neutron detection efficiency is roughly 30%, with a 65- μs die-away time. The die-away time of this counter is not a pure exponential, due in part to the use of novel moderator materials other than polyethylene and to the large size of the cavity. Also noteworthy is the use of 33 fast preamp/discriminators from PD, Inc., rather than the Amptek units used for other multiplicity counters.

J. High-Efficiency Neutron Counter (HENC)

The High-Efficiency Neutron Counter (HENC) is a waste drum counter developed by Canberra Industries and Los Alamos National Laboratory under a Cooperative Research and Development Agreement (CRADA) on evaluation of detector design concepts (Menlove 96). Figure 3.9 is a top view of the HENC taken during a waste assay training school in 1996. This counter was designed to be a high-efficiency, low-detectability limit passive neutron coincidence counter with multiplicity and segmented add-a-source matrix correction capability. An automated drum-handling system is used to open and close the assay chamber door, load and unload drums from the conveyor system, and rotate the drums while they are being assayed. The assay chamber size was set to be the same as the existing Canberra Model JCC-21 Waste Drum Coincidence Counter to reduce design and fabrication costs.



Fig. 3.9. Top view of the High Efficiency Neutron Counter developed by Los Alamos National Laboratory and Canberra Industries.

The design of the HENC was optimized on the basis of a detectability limit figure of merit based on detector efficiency, neutron die-away time, and the detector's active volume and density, which determines the cosmic-ray background. There are a total of 113 ^3He tubes on the sides, top, and bottom of the assay chamber. The neutron detection efficiency is 32%, the die-away time is 50 μs , and the minimum detectability limit is approximately 0.5 mg ^{240}Pu -effective by singles counting and 1.7 mg by doubles counting at sea level. The HENC has performed successfully in the Waste Isolation Pilot Plant (WIPP) NDA Performance Demonstration Program, and the add-a-source and multiplicity features provide information that can be used for safeguards diversion detection.

K. Plutonium Residues Multiplicity Counter

The Plutonium Residues Multiplicity Counter (PRMC) was designed by Canberra Industries based on adaptation of the PSMC design to a larger assay chamber (McElroy 97). The assay cavity is actually 36 cm in diameter x 46 cm high, of which the central 30-cm diameter by 30-cm height is considered to be the active sample volume, with efficiency variation of less than 1% RSD. The PRMC is a “mid-range” performance counter designed to meet facility specifications. Two units have been provided to Rocky Flats for assay of plutonium-bearing salts and residues.

L. Multiplicity Analysis with Conventional Counters

Conventional coincidence counters can sometimes be used as multiplicity counters with the addition of multiplicity electronics and software. However, the performance of such systems cannot match that of counters designed specifically as multiplicity counters. The most serious drawback is lack of neutron detection efficiency, so that counting times may be 4 h or more to obtain the same assay precision as a 15-min. multiplicity counter measurement. In such cases, the count time advantage of neutron counting over calorimetry is completely lost, and calorimeters should be used instead if they are available with appropriate sample cavity sizes. Less obviously, significant assay biases can arise from measurements of heterogeneous samples in counters that are not designed to have flat spatial and energy response profiles. Also, multiplicity deadtime corrections may be very serious (or even give negative results!) in counters with just a few preamplifiers.

One example of a relatively successful use of a conventional counter for multiplicity assay is documented in Rinard (97). A 55-gal. drum pass-through shuffler was used at Savannah River for inventory verification of items that could not fit into smaller counters. Because the shuffler detection efficiency is about a fourth of the efficiency of a multiplicity counter, the required measurement times were about 15 times as long for the same statistical precision. In this case, the inventory was not so large that this restriction was prohibitive. Even so, the assay precision was acceptable only because most of the items contained large masses of plutonium metal, oxide, or MOX, and because assay errors other than counting statistics dominated the measurement errors. In this measurement campaign it was possible to verify most of the small plutonium items with conventional passive coincidence data, but all of the large plutonium items could be verified only with the multiplicity results.

IV. Multiplicity Electronics

A. Overview

The electronics used for thermal neutron multiplicity counters are similar to that used for conventional coincidence counters. They are based on the detection of neutrons with ^3He proportional counters embedded in a polyethylene moderator, and they use the same amplifier electronics system. There are other options for thermal neutron counters, as summarized in Crane (91). Fast neutron multiplicity counting is another alternative, such as the use of plastic scintillators (Ensslin 82), liquid scintillators (Wachter 87), and borated plastic scintillators (Miller 96). At this point in time, the benefits of the thermal neutron counting approach (high-efficiency, energy insensitivity, reliability, and stability) outweigh the potential benefits of fast neutron counting (reduced accidental coincidences and shorter counting times).

This part of the Applications Guide will first describe conventional coincidence electronics components, including the ^3He proportional counter electronics and the conventional shift register electronics, and their associated deadtimes. However, as mentioned in Parts II and III, multiplicity counters will have many more ^3He tubes, for higher efficiency, and many more Amptek preamp/discriminators, for shorter deadtime. Then we will describe some of the differences that are important to multiplicity counting, including the use of derandomizer circuits. The most commonly used multiplicity shift registers are described in sections I through L.

B. Thermal Neutron Detection and Die-Away Time

The process of detecting thermal neutrons involves first moderation then capture in a ^3He proportional counter embedded in the moderator. Neutron moderation is the process by which a neutron collides with matter and loses energy. The most energy will be lost (the best moderation) when the neutron collides with nuclei of similar mass, such as hydrogen (protons) in water or polyethylene. A neutron from spontaneous fission has an initial energy of about 2 MeV, and will be moderated to room temperature, 0.025 eV, by about 27 collisions in hydrogen. This moderation process is essential because the probability of neutron capture in ^3He is largest when the neutrons have energies near thermal (see Crane 91 for the capture cross sections). The capture reaction is

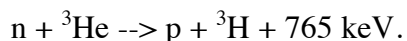

Typically, the multiplicity counter will have 80 to 130 ^3He tubes at 4-atm pressure and 1-in. diameter, with the effective length varied to suit the size of the counter. The reaction energy of 765 keV appears as the kinematic energy of the proton and triton, and is collected as a charge pulse. Some important advantages include very low gamma-ray sensitivity, very high stability, and high intrinsic efficiency for neutrons that strike the ^3He tube (Crane 91).

After moderation, neutrons are lost in the detector by several processes: diffusing out of the detector, diffusing to a ^3He detector tube and being captured and detected, or absorption by hydrogen, cadmium, plutonium, or other neutron absorbers. As a consequence of all these processes, the neutron population in the counter dies away with time in a gradual fashion after a spontaneous fission occurs. In most thermal neutron detectors, the average probability that a given

neutron will be lost as it travels through the counter is nearly constant with time. Under these conditions, the neutron population decreases exponentially in time:

$$N(t) = N(0)e^{-\frac{t}{\tau}} \quad , \quad (4-1)$$

where $N(t)$ is the neutron population at time t , and τ is the mean neutron lifetime in the counter, the “die-away time.”

C. Thermal Neutron Detector Electronics

The neutron capture reaction energy of 765 keV appears in the ^3He tube as the kinematic energy of the proton and triton, and as these particles slow down and ionize the gas, this energy is collected as a charge pulse because of the high voltage applied across the tube wall and its central anode wire. Figure 4.1 illustrates this process and shows the charge collection electronics. The applied high voltage is typically 1500 to 1680 V so that the ^3He tubes are operated in the proportional mode, where the initial ionization charge is amplified by a factor of 10^3 to 10^5 . The ^3He tubes will produce a broad distribution of electrical output pulses depending on the location of the neutron capture in the tube and the direction of the outgoing reaction products. The pulses will have a fast rise time of about $0.1 \mu\text{s}$ due to collection of electrons at the anode, but collection of positive ions at the outer tube wall, the cathode, may take up to $200 \mu\text{s}$. The recovery time of a ^3He tube, the time before it can provide another output pulse, which may overlap a previous pulse, is typically 1 to 2 μs .

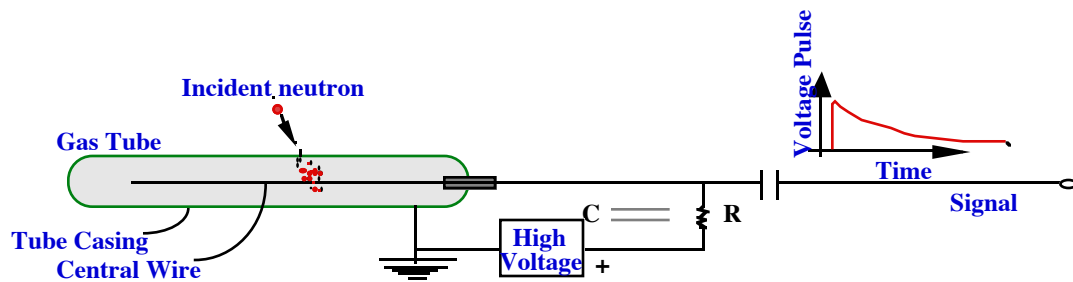

Fig. 4.1. The neutron capture process in ^3He tubes and the associated charge collection electronics.

Typically, Amptek integrated circuits are used to amplify the tube output pulses, set the counting threshold, and convert the pulses above the threshold to digital pulses. This circuit, manufactured by AMPTEK, Inc., of Bedford, Massachusetts, consists of a Model A-111 hybrid charge-sensitive preamplifier, an amplifier with a bipolar output, a discriminator set to provide 50 ns output pulses, and a pulse-shaping circuit. The Amptek circuit provides sufficient gain and signal-to-noise ratio if the ^3He tubes are operated at about +1680 V and has an effective time constant of about 150 ns. This defines the minimum recovery time of the Amptek, the time before it can provide another 50-ns-wide output pulse. Each Amptek is mounted on a small circuit board that also provides an output pulse to drive one light-emitting diode (LED) that flashes whenever a neutron is detected. Figure 4.2 illustrates one Amptek channel processing the input signals from three ^3He tubes.

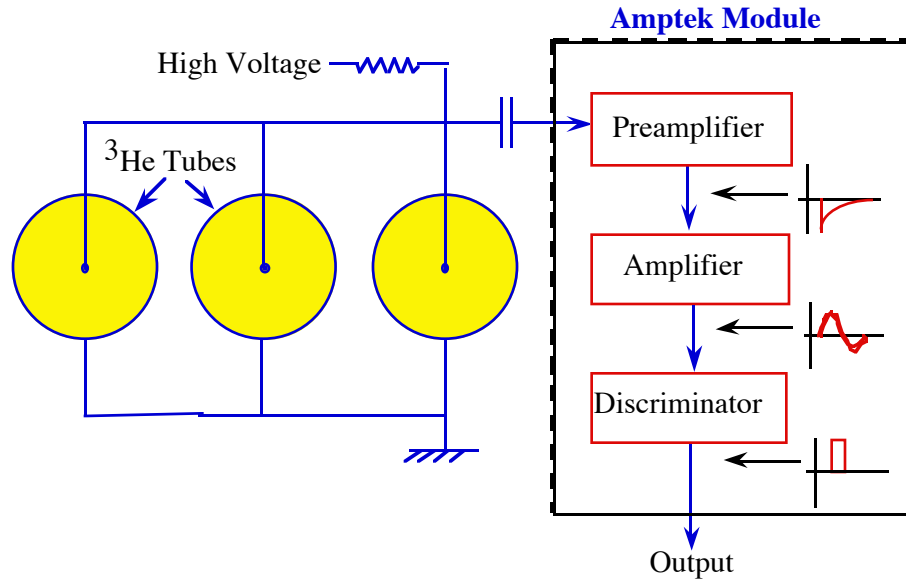

Fig. 4.2. Electronic layout with one Amptek channel processing the input signals from three ^3He tubes.

The physical layout of the tubes and Amptek circuit boards on the Plutonium Scrap Multiplicity Counter is visible in Fig. 3.3. The ^3He tubes are screwed into the bottom of a cylindrical junction box to provide good grounding. The junction box is split into two horizontal layers, with the bottom one providing the high-voltage (HV) distribution lines and isolation capacitors shown in Fig. 4.1. The top layer holds the Amptek boards, the wires required to provide the boards with +5V DC operating power, and the 50-ns discriminator output lines. Also, all of the LED output signals from all of the Amptek boards are brought out to a single display panel on the side of the junction box. This provides the operator with a quick visual diagnostic to ensure that all Amptek channels are operating during sample assays. The junction box is sealed with a tight-fitting lid with an O-ring seal, and is equipped with several self-indicating desiccant holders. This is intended to prevent HV breakdown in the HV distribution network, which can cause electronic noise bursts that are detected as spurious coincidence events.

Figure 4.3 shows how the individual Amptek modules can be connected together via an OR circuit to provide a single input line to the shift register circuitry. The use of many Ampteks greatly reduces the overall counting deadtime of the counter, because it's unlikely that the following neutrons from a fission event will enter the same ^3He tube as the first one. However, the OR-gate has a deadtime due to accidental overlap of the 50-ns input pulses. For n Amptek modules, the deadtime is given by (Ensslin 91a)

$$\text{OR-gate-deadtime} = \left(\frac{n-1}{n} \right) (50\text{ns}) \quad . \quad (4-2)$$

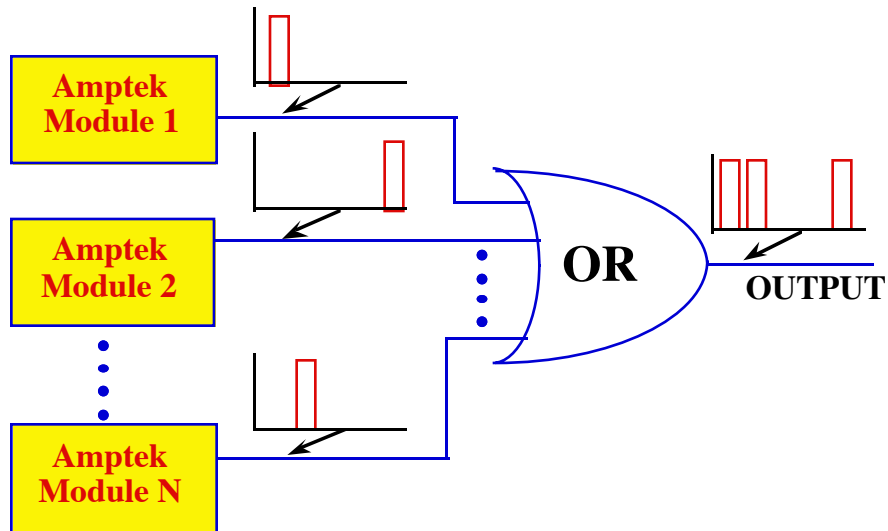

Fig. 4.3. Electronic layout (simplified) of multiple Amptek modules connected together via an OR circuit to provide a single output line.

D. Derandomizer Circuit

The OR circuit described in the preceding section can be replaced with a derandomizer input circuit that eliminates this source of deadtime. This circuit can be a very useful addition to coincidence counters operating at high count rates, or to multiplicity counters because the triples counts are very sensitive to deadtime. The derandomizing buffer holds pulses that are waiting to enter the shift register, thus eliminating the input synchronization losses given by Eq. 4-2. Input pulses separated by less than 100 ns—the clock period of the circuit—are stored in buffers until the coincidence or multiplicity shift register can accept them. The word “derandomizer” refers to the fact that the initial input events are now “quantized” into periodic 100-ns-long time intervals.

The most recently developed derandomizing circuit is implemented in a single Actel field-programmable gate array (FPGA) that can be installed directly in the high-voltage junction box with the Amptek circuits (Bourret 94). The derandomizer consists of 32 input channels that can hold up to three events from each of 32 Amptek circuits. There are seven outputs: four groups of eight channels each, two groups of 16 channels each, and one group of all 32 summed channels. These groupings were selected to facilitate detector ring-ratio measurements. The outputs are clocked at a 10-MHz synchronous rate and produce a 50-ns pulse for each input event. With this derandomizing circuit, a conventional shift register can be operated at count rates approaching 2 MHz with virtually no synchronizer counting losses. A multiplicity counter will have a triples deadtime correction of about 50% at a count rate of 500 to 900 kHz.

E. The Neutron Pulse Stream and Rossi- α Distribution

The Amptek modules and OR gates described above provide a stream of electronic pulses, each representing one detected neutron, to the input of the coincidence circuit. The pulse stream contains some combination of spontaneous fission, induced fission, (α, n) neutrons, and external background events. Figure 4.4 illustrates a neutron pulse stream that contains both correlated and uncorrelated events. Using this pulse stream, we need to separate out the correlated neutron events that are the quantitative signature for plutonium from the background of uncorrelated neutron

events. We cannot distinguish individual neutrons, the order of neutrons in coincidences, or which individual neutrons are fission coincidences and which are (α,n) neutrons. The mathematical basis for defining correlated and uncorrelated neutrons is given in Part V below. Here we just need to distinguish their time dependence to understand the operation of the shift register coincidence circuits.

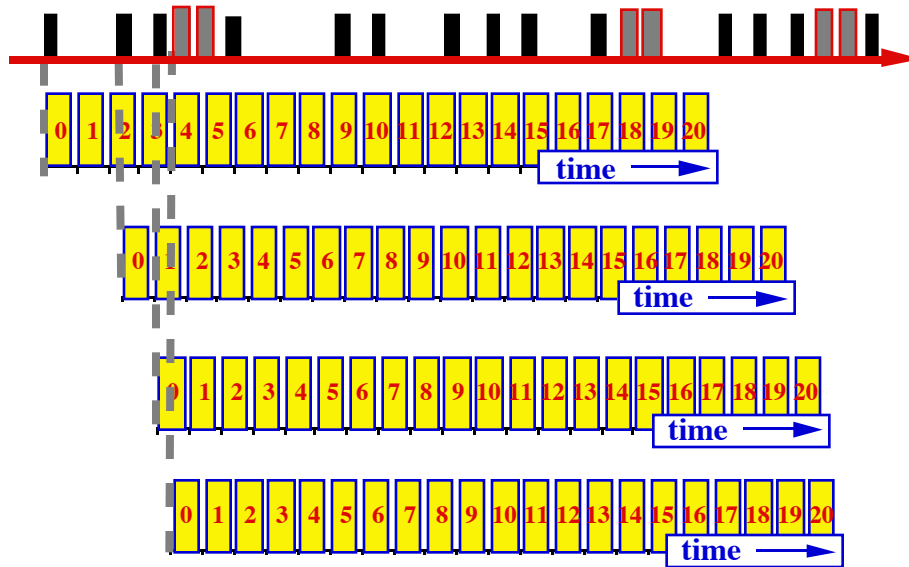

Fig. 4.4. A neutron pulse stream that contains both correlated (striped bars) and uncorrelated (black bars) events.

The Rossi- α distribution, developed for reactor noise analysis, is the distribution in time of events that follow after an arbitrarily chosen starting event. If only random, uncorrelated events are being detected, the distribution is on the average constant in time. If correlated events from fission are also present, then the Rossi- α distribution is given by

$$N(t) = A + R e^{-\frac{t}{\tau}} \quad (4-3)$$

$N(t)$ is the height of the distribution at time t , A is the accidental or random count rate, and R is the real or correlated count rate. Figure 4.5 is a histogram of the Rossi- α distribution associated with the neutron pulse stream shown in Fig. 4.4. The initial trigger events at $t=0$ can be either correlated or uncorrelated events. The dark bars represent fission neutrons correlated to the initial pulse (the R rate in Eq. 4-3). The striped bars are neutrons from fissions that are not correlated to the initial event, either because the initial event was a random neutron or because it was from a different fission. The white bars are uncorrelated background neutrons, or neutrons from fissions where only a single neutron was detected. Note that the accidental rate A contains both of these components.

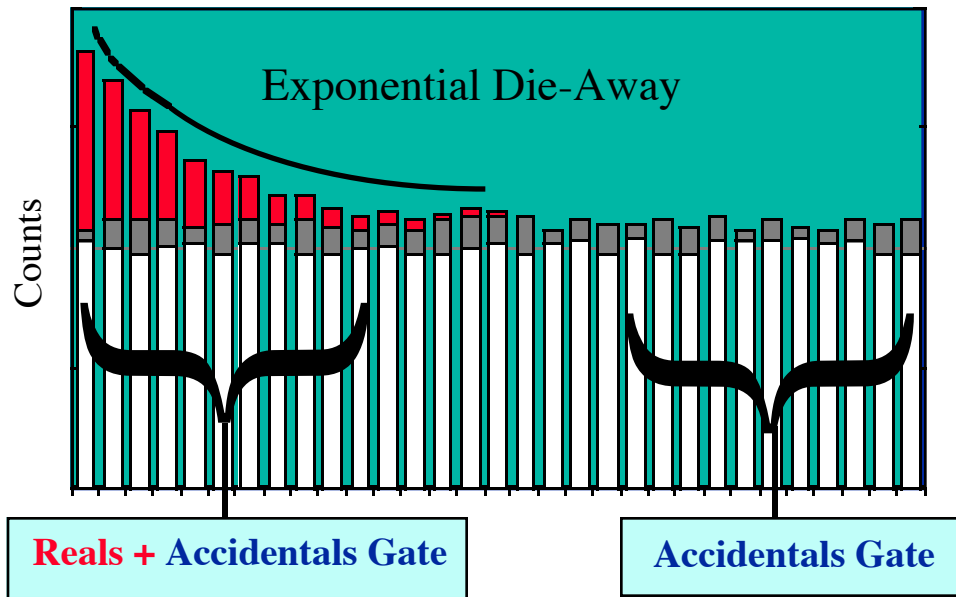

Fig. 4.5. Histogram of a Rossi- α distribution associated with the neutron pulse stream shown in Fig. 4.4. An actual measured distribution with exponential die-away time is superimposed above the histogram, and the (Reals + Accidentals) and (Accidentals) coincidence counting gates are superimposed at the bottom of the histogram.

Figure 4.5 also shows two coincidence counting intervals superimposed, the R+A (Reals plus Accidentals) and A (Accidentals only). These are described in Section G below.

F. Predelay Circuit

In Fig. 4.5, an example of an actual Rossi- α distribution with an exponential die-away time is superimposed above the histogram. Note that the actual distribution does not continue as a rising exponential all the way down to $t=0$. This is because of small electronic deadtimes or pulse pileup effects in the ^3He tubes, Ampteks, OR gates, or other components. The most important cause of pulse pileup is usually amplifier baseline displacement following a pulse. Any closely following pulses that fall on the displaced bipolar baseline of the Amptek amplifier before it is fully restored to zero may have a higher or lower probability of triggering the discriminator. Bias resulting from pulse pileup is proportional to the square of the count rate and may become noticeable only at high count rates.

To reduce these deadtime and pileup effects, a short shift register called the “predelay” is located at the input to the coincidence or multiplicity shift register circuits (see for example the conventional shift register circuit shown in Fig. 4.6). This circuit delays the start of the coincidence counting interval for the R+A gate until a short time interval PD (the predelay) has passed. The length of the predelay is typically 3 to 4.5 μs . If it were not present, the effective length of the R+A gate would be reduced by some poorly determined time of 1 to 2 μs or more, depending on the count rate. Then the R+A gate would be shorter than the A gate, and a counting imbalance would result. “Bias” is defined as the difference between the R+A and A counting rates when a random source such as AmLi is used. For a random source the difference should be zero. If it is not, the percent bias is 100 R/A .

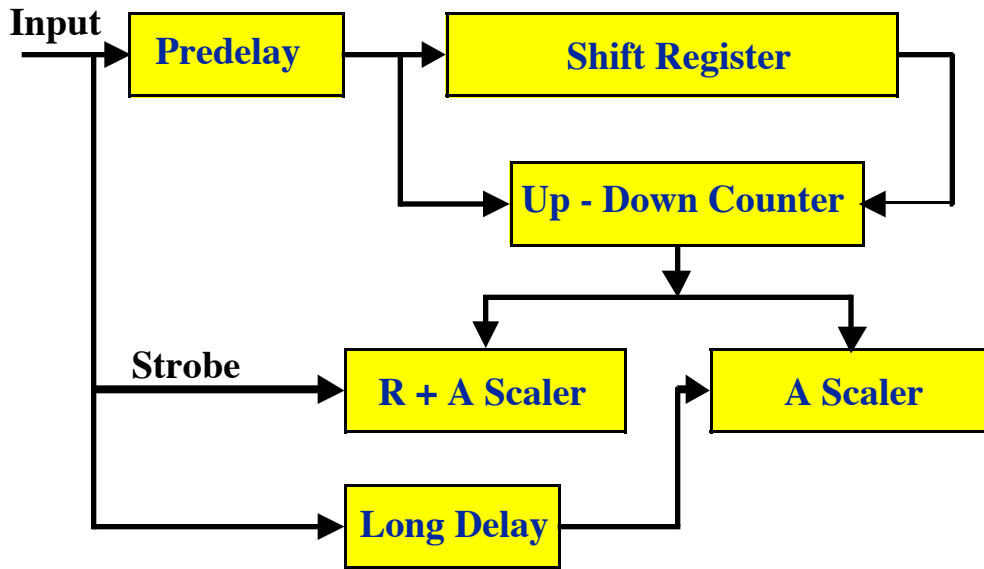

Fig. 4.6. Conventional shift register circuit.

It is important to select the length of the predelay based on the speed of the amplifier, the storage capacity of any derandomizer that is used, and the expected count rate. If the amplifier baseline is not fully restored in a time less than the predelay, the effect will extend into the R+A gate and a bias will result. The Amptek A-111 amplifier requires a predelay of only 3 μs for a bias of less than 0.01% at a count rate of 500 kHz. Also, as the derandomizing buffer stretches pulse strings out in time, it may create strings longer than the predelay and thereby produce a bias. If the multiplicity counter is expected to operate at singles count rates in excess of 500 kHz, the predelay setting and the remaining bias should be checked with a strong AmLi source.

G. Conventional Shift Register Basics

The goal of the conventional coincidence shift register circuit is to separate the incoming neutron pulse stream into correlated and uncorrelated events, and thereby provide a quantitative measure of a sample's fission rate. The shift register, shown in Fig. 4.6, achieves this in an elegant fashion. All neutrons are "remembered" by the shift register, enabling it to collect all possible neutron pairs in an inherently deadtime-free manner. This is done by storing all incoming pulses for a predetermined coincidence interval, the gate width G , in an integrated circuit called a shift register. The circuit consists of a series of clock-driven flip-flops linked together in stages. For example, a 128-stage shift register driven by a 4-MHz clock (0.25 $\mu\text{s}/\text{stage}$) defines a gate G of 32 μs . Incoming pulses shift through the register one stage at a time and the whole process takes 32 μs .

Operation of the shift register coincidence circuit can be visualized in terms of the Rossi- α distribution shown in Fig. 4.5. This figure shows a prompt gate of width G that opens after the predelay PD and that collects real and accidental coincidences. After a delay much longer than the neutron die-away time in the detector (modern circuits use up to 4096 μs), another gate is opened that collects only accidental events. The difference between the counts collected in the R+A gate

and those collected in the A gate is the desired real signal R (or that fraction of R that lies within the gate width G).

The shift register collects the counts in the R+A and A gates without explicitly measuring the entire Rossi- α distribution. Every input event passes through the predelay and then passes into and through the R+A gate. Figure 4.7 compares this process to an escalator. Every event that gets on the escalator increments an up-down counter, and every event that gets off decrements the up-down counter, so that this counter keeps a running tally of the total counts in the shift register. Every input pulse, before it enters the predelay and the shift register, also provides a strobe pulse that transfers the current contents of the up-down counter to an accumulator that serves as the R+A scaler.

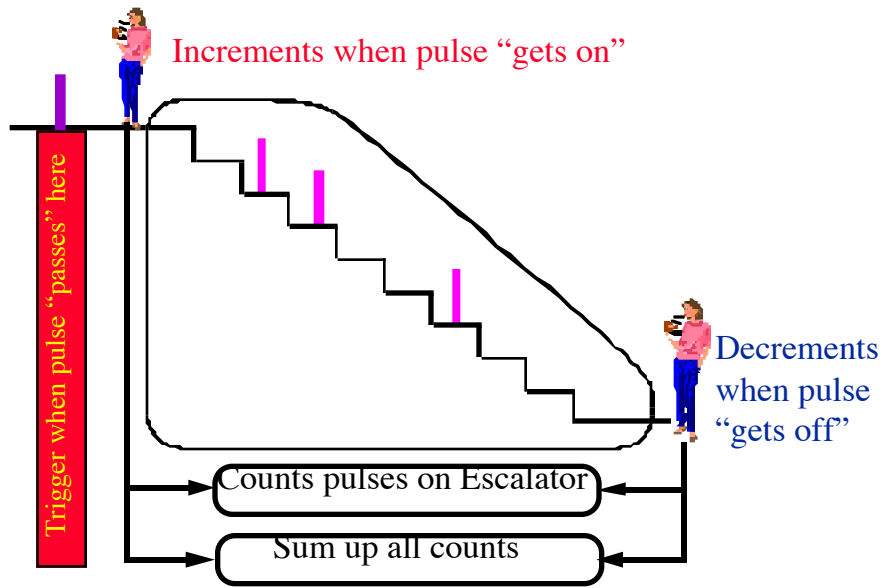

Fig. 4.7. Comparison of the shift register circuit to an escalator.

This counting algorithm records all possible pairs of coincidences between events. An example is given in Fig. 4.8. As four pulses pass through the shift register, the number on the escalator is 0, 1, 2, and finally 3 counts. The accumulator count rises from 0 to 1, then 3, then 6. Figure 4.9 shows that 6 is the total number of possible coincidences between 4 events, and that in general the number of coincidences recorded for n closely following events is $n(n-1)/2$. This equation is the reduced second factorial moment of the distribution $P(n)$ of incoming neutrons, as described in detail in Part V of this guide. Note that the possible permutations in counting two-fold coincidences can exceed the number of events.

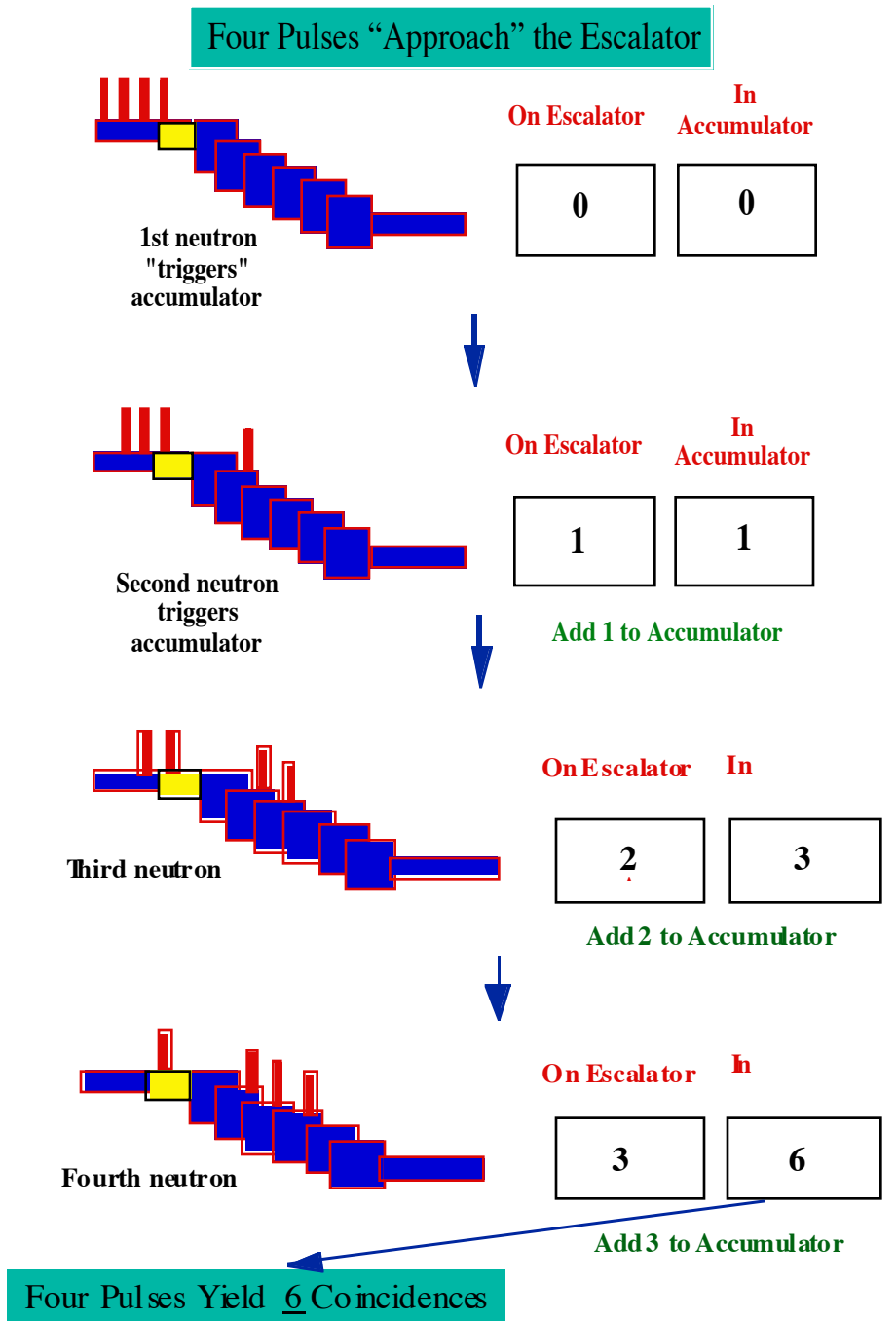

Fig. 4.8. Example of shift register operation as four neutron pulses pass through the shift register.

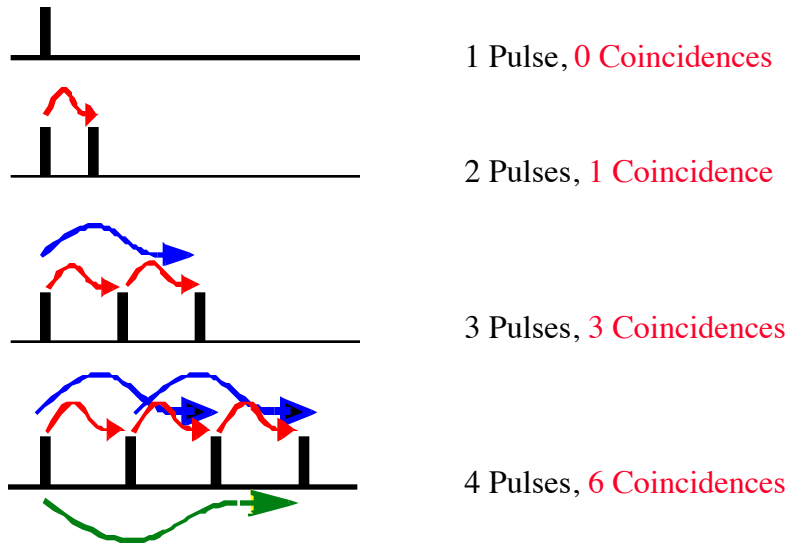

Fig. 4.9. Illustration of the total number of possible coincidence pairs between 1, 2, 3, or 4 neutron pulses.

The coincidence events in the R+A gate can represent two or more neutrons from a real fission event, or just the random overlap of background neutrons or neutrons from different fissions, as illustrated in the Rossi- α distribution in Fig. 4.5. To separate out the accidental coincidences, a second accumulator is introduced, but the strobe that triggers this accumulator is delayed by 4096 μ s. Because this delay is much longer than the neutron die-away time in the detector, it's extremely unlikely that any correlated events will be collected. Hence this second scaler collects only accidental events. The number of accidental events collected in the A scaler will be the same as those in the R+A scaler within counting statistics, so that the difference between the R+A and A scalers is R. The accidental count rate A is related to the singles count rate S by the equation

$$A = GS^2 \quad (4-4)$$

This nonlinear relationship shows that A will exceed S when the singles count rate is greater than 1/G. Because Eq. 4-4 must hold within counting statistics, unless the background is fluctuating tremendously, it provides an excellent diagnostic check on the operation of shift register circuitry.

H. Multiplicity Shift Register Basics

There is more information in a neutron pulse stream than just single and double neutron events. In multiplicity counting, we look at the distribution of 0's, 1's, 2's, 3's, etc. in the coincidence gates to deduce the multiplicity distribution of the neutron events. Special multiplicity electronics are required to measure the neutron multiplicity distributions in the R+A and A coincidence gates. The multiplicity measurement records the number of times each multiplicity occurs in the coincidence gates. For example, if seven neutron pulses are in a coincidence gate when another neutron arrives, then "1" is added to the counter that tallies multiplicities of seven. Figure 4.10 is a simplified circuit diagram for a multiplicity shift register.

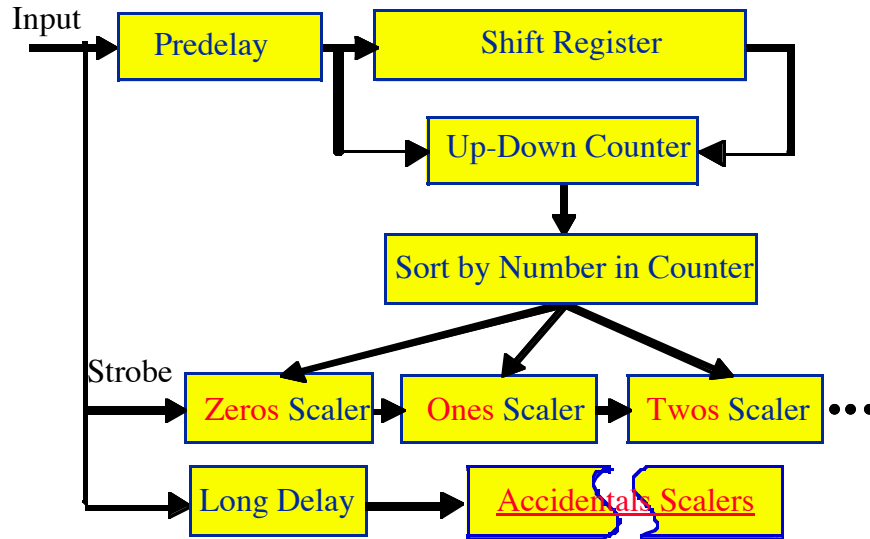

Fig. 4.10. Multiplicity shift register circuit.

Separate multiplicity distributions are measured for the R+A and A coincidence gates. Table 4.1 shows typical R+A and A multiplicity distributions measured with a 60-g plutonium oxide sample measured in a multiplicity counter with roughly 56% neutron detection efficiency. Each distribution contains the number of times each multiplicity occurred in the corresponding gate. As an example from this table, seven neutron pulses were found 183 times in the R+A coincidence gate, and 42 times in the A coincidence gate.

Multiplicity	Counts (R+A Gate)	Counts (A Gate)
0	26804360	29731130
1	8187530	6222207
2	1772831	1016603
3	325270	157224
4	53449	22387
5	8231	3093
6	1237	402
7	183	42
8	30	8
9	2	1
10	0	0

The sum of all the multiplicities in the A distribution (37,153,097) is the total number of triggers, because the singles scaler is situated at the output of the A scaler. The sum of all the multiplicities in the R+A distribution (37,153,123) is not always equal to the total number of triggers because the R+A gate interval is shifted by about 4 ms from that of the A gate. For a purely random pulse stream, the two distributions are the same within statistical errors. For a

correlated pulse stream, the R+A distribution has more high-multiplicity events, and the A distribution has more events with multiplicity 0 (i.e., a trigger with no following events).

The two distributions in Table 4.1 can be analyzed to obtain the number of single, double and triple neutron pulses. But note that the number of 1's, 2's, and 3's in Table 4.1 above is not what we call the singles, doubles, and triples! Instead, the singles rate is the sum of all the triggers divided by the count time. The doubles rate is the sum of all the triggers divided by the count time, times the mean of the R+A distribution minus the mean of the A distribution (see Eq. 5-15 in Part V). The doubles is the same as the conventional shift register output. The triples is a more complex unfolding of the R+A and A distributions, and is given by Eq. 5-16 in Part V. Of course, a conventional shift register cannot determine the triples because it does not measure the multiplicity distributions.

The reason that we have to measure very high multiplicities, 8's, 9's, 10's, etc., is that the average number of events inside the gate width of the shift register is the singles count rate times the gate width. For example, if the singles rate is 100,000 counts/s, and the gate width is 64 μ s, the average number of events in either the R+A or the A gate at any given time is 6.4. So even for a purely random neutron source, we will record two R+A and A multiplicity distributions that range from 0's to 15's or 20's, with their peak around 6 or 7.

I. Los Alamos MSR4/Canberra 2150 Multiplicity Shift Register

The first multiplicity shift register developed at Los Alamos National Laboratory for in-plant assay applications was the Model MSR4 (Halbig 91), built as a double-wide nuclear instrumentation module (NIM module). It was preceded by several prototype designs used for multiplicity counter development activities. It is now commercially available through Canberra Industries as a single-wide NIM module called the Canberra Model 2150.

The MSR4 described in Halbig (91) is built on application-specific programmable logic chips that operate on +12V, -12V, and +5V power supplies at a clock speed of 4 MHz. Figure 1 of Halbig (91) is a detailed block diagram of the circuitry. The singles counting register is 32 bits deep, and the R+A and A registers are 44 bits deep. There are 256 multiplicity registers for the R+A gate and 256 for the A gate, all of which are 8 bits deep before overflow and readout is required. Registers 0 through 254 record multiplicity events ranging from single neutrons (trigger without any following events) through 255 neutrons (trigger plus 254 following events). Register 255 records all multiplicities of 255 and higher. There is no front panel display, and the unit must be controlled and read out through a serial interface with a computer. The Canberra 2150 version includes a +5V power supply for the Ampteks, but it can only power a limited number.

J. Los Alamos PSR/Aquila PSR-B Multiplicity Shift Register

The Portable Shift Register (PSR) is a small, battery-operated shift register package that was developed to address applications not covered by the larger existing electronics packages (Halbig 94). The PSR makes extensive use of hardware and software developed for the Miniature Modular Multichannel Analyzer, and includes an upgraded version of the MSR4 multiplicity shift register. Commercial versions called the PSR-B were manufactured by Aquila Technologies, Inc.

The PSR is built on the same application-specific programmable logic chips, operated at 4 MHz, as the MSR4 described in Halbig (91). The coincidence gate width G can be varied from 0.25 to 1024 μ s in steps of 0.25 μ s, and the predelay can be varied from 0 to 1023.75 μ s in steps of 0.25 μ s. The long delay between the R+A and A gates is fixed at 4096 μ s. The singles

counting register is 36 bits deep, and the R+A and A registers are 48 bits deep. There are 256 multiplicity registers for the R+A gate and 256 for the A gate, all of which are 32 bits deep. This provides the PSR with the ability to operate at high count rates for long counting periods without overflowing the registers that collect the multiplicity distribution. Two auxiliary scalers, each 40 bits deep, are available to process additional information. The PSR also includes +5V and +200–2000V power supplies to operate the multiplicity counter's ^3He tubes and Amptek electronics. The +5V power supply can only power a limited number of Ampteks.

K. Canberra JSR-14 Multiplicity Shift Register

The Canberra JSR-14 is a compact multiplicity shift register based on the Los Alamos MSR4 and Canberra 2150 modules. It is built into the same small case as the Canberra InSpector multichannel analyzer. The JSR-14 has an on/off indicator light and a HV on/off indicator light, but like its predecessors it is controlled and read out through a serial interface with a computer. The unit includes an additional totals counter, and a burst pulser for diagnostics.

L. Los Alamos PATRM List Mode Module

Another approach to multiplicity electronics is to use a time correlation analyzer to collect all of the time intervals between the incoming pulses as they arrive. The Pulse Arrival-Time Recording Module (PATRM) was developed at Los Alamos National Laboratory for a variety of applications (Arnone 92). These include neutron multiplicity analysis, deadtime and diagnostic studies, delayed neutron counting, analysis of critical systems, and time-dependent multiplicity measurements during neutron interrogation. It is commercially available through BNFL Instruments for multiplicity analysis of waste drums.

The PATRM is a computer-automated measurement and control (CAMAC) module capable of recording the arrival time of up to 4 million pulses. The result is a list of 32-bit binary numbers that represents the pulse arrival time, scaled with a 10-MHz clock. This information can be processed by the computer in a variety of ways, including phantom shift register analysis with different gate width choices, or randomly triggered signal analysis (Feynman Variance) (Brunson 97). For example, large bursts of pulses due to cosmic-ray events can be identified and deleted from the analysis. At the present time, the PATRM is best suited for low and moderate count rate applications because the computer will require some time to process and analyze the collected pulses after every 4 million pulses. An updated version of the PATRM is under development that will incorporate a 100-MHz clock and label each pulse with the channel from which it came (Arnone 96). This version will be configured as a single PC card installable in any high-performance, IBM-type computer.

V. Multiplicity Mathematics

A. Overview

This section provides equations for ^{240}Pu mass and other sample parameters in terms of the neutron time distributions that can be measured with a multiplicity counter. The starting point for these equations is the spontaneous fission process in plutonium, which provides the assay signature for multiplicity counting as it does for conventional coincidence counting. Section B provides the background information on this process that is needed for the derivations. Most plutonium samples also emit neutrons from (α,n) reactions with matrix materials, and information on this reaction is provided in Section C. Neutrons from either spontaneous fission or (α,n) reactions can induce fissions in the sample, and this self-multiplication process is described in Section D.

The equations are based on certain fundamental assumptions about the fission process and the sample, which sets limits on their accuracy and range of applicability. These assumptions are outlined in Section E. Then, in Section F, we define the factorial moments that are the mathematical basis for the equations.

Then we proceed down two separate paths by providing two different sets of equations for the moments of the correlated neutron distributions produced by spontaneous and induced fissions in a plutonium sample:

1. One set of equations describes the correlated moments in terms of the distributions that can be obtained from the neutron multiplicity counter. Section G describes the measured foreground and background distributions. Then, Section H shows how the actual correlated distributions can be extracted from them, and how singles, doubles, and triples can be defined in terms of these correlated moments.

2. The other set of equations describes the correlated moments in terms of analytical expressions based on the properties of the sample. The emitted fission multiplicity distribution is described in Section I, and the detected distribution in Section J. The definition of singles, doubles, and triples in terms of factorial moments is given in Section K. Then, Section L provides analytical expressions for the fractions of the correlated events that lie within the coincidence gate fraction.

The two sets of equations contain everything that we need: (1) how singles, doubles, and triples can be extracted from the multiplicity electronics, and (2) how singles, doubles, and triples reflect the sample properties. Then Section M provides the final solutions for ^{240}Pu mass, self-multiplication, and (α,n) reaction rate. An alternative solution for ^{240}Pu mass, (α,n) reaction rate, and detector efficiency is given in Section N.

B. The Spontaneous Fission Process

The primary source of spontaneous fission neutrons in plutonium is usually the isotope ^{240}Pu . The emitted multiplicity distribution from ^{240}Pu is shown in Figure 5.1. (Figure 5.1 also includes the multiplicity distribution for 2-MeV neutron-induced fission in ^{239}Pu .) The spontaneous fission neutron yields of the plutonium isotopes and other related nuclides are summarized in Table 5.1 (Ensslin 91a). Other multiplicity distributions for both spontaneous and induced fission will have similar shapes, but different values for the average multiplicity $\bar{\nu}$. All of these distributions can be approximated by a Gaussian distribution centered at $\bar{\nu}$ and having a

width σ . A distribution width of 1.08 can be used as an approximation for all isotopes except ^{252}Cf , where 1.21 should be used (Terrell 57).

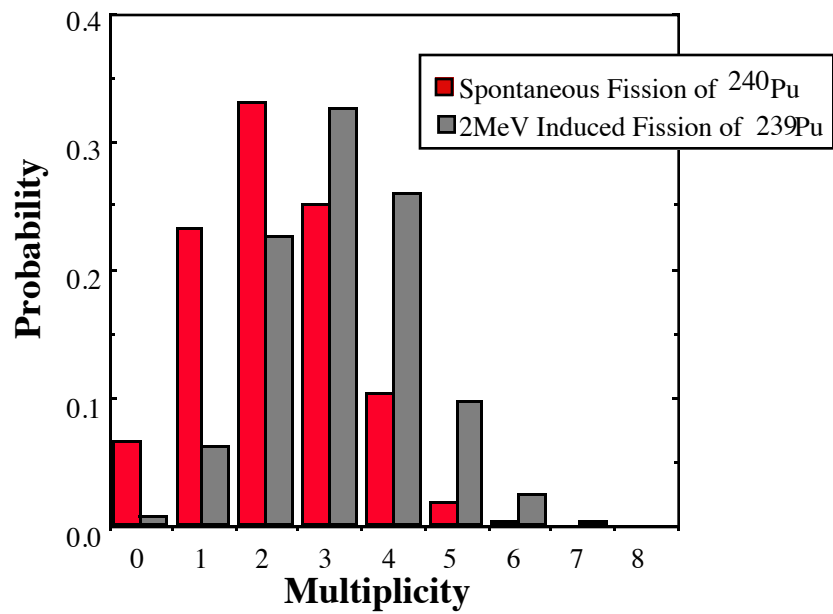

Fig. 5.1. The spontaneous fission multiplicity distribution for ^{240}Pu (solid bars) and the 2-MeV-neutron-induced induced fission multiplicity distribution for ^{239}Pu (striped bars).

Table 5.1. The spontaneous fission neutron yields of the plutonium isotopes and other related nuclides (from Ensslin 91a).

Isotope A	Number of Protons Z	Number of Neutrons N	Total Half-Life	Spontaneous Fission Half-Life (yr)	Spontaneous Fission Yield (n/s-g)	Spontaneous Fission Multiplicity ν	Induced Thermal Fission Multiplicity ν
²³² Th	90	142	1.41 X 10 ¹⁰ yr	>1 X 10 ²¹	>6 X 10 ⁻⁸	2.14	1.9
²³² U	92	140	71.7 yr	8 X 10 ¹³	1.3	1.71	3.13
²³³ U	92	141	1.59 X 10 ⁵ yr	1.2 X 10 ¹⁷	8.6 X 10 ⁻⁴	1.76	2.4
²³⁴ U	92	142	2.45 X 10 ⁵ yr	2.1 X 10 ¹⁶	5.02 X 10 ⁻³	1.81	2.4
²³⁵ U	92	143	7.04 X 10 ⁸ yr	3.5 X 10 ¹⁷	2.99 X 10 ⁻⁴	1.86	2.41
²³⁶ U	92	144	2.34 X 10 ⁷ yr	1.95 X 10 ¹⁶	5.49 X 10 ⁻³	1.91	2.2
²³⁸ U	92	146	4.47 X 10 ⁹ yr	8.20 X 10 ¹⁵	1.36 X 10 ⁻²	2.01	2.3
²³⁷ Np	93	144	2.14 X 10 ⁶ yr	1.0 X 10 ¹⁸	1.14 X 10 ⁻⁴	2.05	2.70
²³⁸ Pu	94	144	87.74 yr	4.77 X 10 ⁹	2.59 X 10 ³	2.21	2.9
²³⁹ Pu	94	145	2.41 X 10 ⁴ yr	5.48 X 10 ¹⁵	2.18 X 10 ⁻²	2.16	2.88
²⁴⁰ Pu	94	146	6.56 X 10 ³ yr	1.16 X 10 ¹¹	1.02 X 10 ³	2.16	2.8
²⁴¹ Pu	94	147	14.35 yr	(2.5 X 10 ¹⁵)	(5 X 10 ⁻²)	2.25	2.8
²⁴² Pu	94	148	3.76 X 10 ⁵ yr	6.84 X 10 ¹⁰	1.72 X 10 ³	2.15	2.81
²⁴¹ Am	95	146	433.6 yr	1.05 X 10 ¹⁴	1.18	3.22	3.09
²⁴² Cm	96	146	163 days	6.56 X 10 ⁶	2.10 X 10 ⁷	2.54	3.44
²⁴⁴ Cm	96	148	18.1 yr	1.35 X 10 ⁷	1.08 X 10 ⁷	2.72	3.46
²⁴⁹ Bk	97	152	320 days	1.90 X 10 ⁹	1.0 X 10 ⁵	3.40	3.7
²⁵² Cf	98	154	2.646 yr	85.5	2.34 X 10 ¹²	3.757	4.06

The ²⁴⁰Pu distribution, normalized to one, is tabulated in Table 5.2 (Ensslin 91b, Boldeman 85, Holden, Zucker 84) along with the spontaneous fission distributions for the minor fertile isotopes ²³⁸Pu and ²⁴²Pu and the reference material ²⁵²Cf. For completeness, Table 5.2 includes ²⁴²Cm and ²⁴⁴Cm, and the induced fission multiplicity distribution for ²³⁹Pu at thermal energies (0.025 eV) and fission spectrum energies (2 MeV) (Zucker 86).

Table 5.2. Spontaneous and induced fission multiplicity distributions.								
P(v)	²³⁸ Pu s.f.	²⁴⁰ Pu s.f.	²⁴² Pu s.f.	²⁴² Cm s.f.	²⁴⁴ Cm s.f.	²⁵² Cf s.f.	²³⁹ Pu .025 eV	²³⁹ Pu 2 MeV
0	0.054	0.066	0.068	0.021	0.015	0.002	0.011	0.006
1	0.205	0.232	0.230	0.147	0.116	0.026	0.099	0.061
2	0.380	0.329	0.334	0.327	0.300	0.127	0.275	0.227
3	0.225	0.251	0.247	0.327	0.333	0.273	0.327	0.326
4	0.108	0.102	0.099	0.138	0.184	0.304	0.205	0.259
5	0.028	0.018	0.018	0.037	0.043	0.185	0.073	0.096
6		0.002	0.003	0.003	0.009	0.066	0.010	0.022
7				0.001		0.015	0.001	0.003
8						0.002		0.001
ν_1	2.21	2.156	2.145	2.540	2.720	3.757	2.876	3.163
ν_2	3.957	3.825	3.794	5.132	5.939	11.962	6.748	8.240
ν_3	5.596	5.336	5.317	8.036	10.101	31.812	12.589	17.321

Table 5.2 shows that the actual number of neutrons emitted in each fission can vary from 0 to 6, or more depending on the kinematics of the fission process. These multiplicity distributions are normalized to 1, and have a mean value ν_1 :

$$\sum_{\nu=0}^{\max} P(\nu) = 1 \quad \text{and} \quad \sum_{\nu=0}^{\max} \nu P(\nu) = \nu_1 \quad . \quad (5-1)$$

Also, the first three factorial moments ν_1 , ν_2 and ν_3 of these multiplicity distributions (defined in Section F below) are tabulated at the bottom of Table 5.2.

For ^{240}Pu , the average number of neutrons emitted per spontaneous fission, or the mean multiplicity ν_1 , is 2.156. From the ^{240}Pu spontaneous fission yield of 1020n/s-g in Table 5.1, and the mean spontaneous fission multiplicity of 2.156, we can deduce that ^{240}Pu has a spontaneous fission rate F of about 473 fissions/s-g. The spontaneous fission neutron energy spectrum follows a Maxwellian distribution and has an average energy of about 1.96 MeV for ^{240}Pu and 2.14 MeV for ^{252}Cf .

C. Description of (α ,n) Reactions

Many heavy nuclei, including the odd and even isotopes of plutonium, decay by alpha particle emission as well as by spontaneous fission. Table 5.3 (Ensslin 91a) summarizes the alpha decay half-lives and yields for these nuclei. From Tables 5.1 and 5.3 we see that, in fact, alpha decay is a much more common decay mode than spontaneous fission, even for the heaviest nuclide on the list, ^{252}Cf .

Table 5.3. Summary of alpha decay half-lives and yields of the plutonium isotopes and other related nuclides (from Ensslin 91a).

Isotopic A	Total Half-Life	Alpha Decay Half-Life	Alpha Yield (α /s-g)	Average Alpha Energy (MeV)	(α ,n) Yield in Oxide (n/s-g)	(α ,n) Yield in UF6/PuF4 (n/s-g)
²³² Th	1.41 X 10 ¹⁰ yr	1.41 X 10 ¹⁰ yr	4.1 X 10 ³	4.00	2.2 X 10 ⁻⁵	
²³² U	71.7 yr	71.7yr	8.0 X 10 ¹¹	5.30	1.49 X 10 ⁴	2.6 X 10 ⁶
²³³ U	1.59 X 10 ⁵ yr	1.59 X 10 ⁵ yr	3.5 X 10 ⁸	4.82	4.8	7.0 X 10 ²
²³⁴ U	2.45 X 10 ⁵ yr	2.45 X 10 ⁵ yr	2.3 X 10 ⁸	4.76	3.0	5.8 X 10 ²
²³⁵ U	7.04 X 10 ⁸ yr	7.04 X 10 ⁸ yr	7.9 X 10 ⁴	4.40	7.1 X 10 ⁻⁴	0.08
²³⁶ U	2.34 X 10 ⁷ yr	2.34 X 10 ⁷ yr	2.3 X 10 ⁶	4.48	2.4 X 10 ⁻²	2.9
²³⁸ U	4.47 X 10 ⁹ yr	4.47 X 10 ⁹ yr	1.2 X 10 ⁴	4.19	8.3 X 10 ⁻⁵	0.028
²³⁷ Np	2.14 X 10 ⁶ yr	2.14 X 10 ⁶ yr	2.6 X 10 ⁷	4.77	3.4 X 10 ⁻¹	
²³⁸ Pu	87.74 yr	87.74 yr	6.4 X 10 ¹¹	5.49	1.34 X 10 ⁴	2.2 X 10 ⁶
²³⁹ Pu	2.41 X 10 ⁴ yr	2.41 X 10 ⁴ yr	2.3 X 10 ⁹	5.15	3.81 X 10 ¹	5.6 X 10 ³
²⁴⁰ Pu	6.56 X 10 ³ yr	6.56 X 10 ³ yr	8.4 X 10 ⁹	5.15	1.41 X 10 ²	2.1 X 10 ⁴
²⁴¹ Pu	14.35 yr	5.90 X 10 ⁵ yr	9.4 X 10 ⁷	4.89	1.3	1.7 X 10 ²
²⁴² Pu	3.76 X 10 ⁵ yr	3.76 X 10 ⁵ yr	1.4 X 10 ⁸	4.90	2.0	2.7 X 10 ²
²⁴¹ Am	433.6 yr	433.6 yr	1.3 X 10 ¹¹	5.48	2.69 X 10 ³	
²⁴² Cm	163 days	163 days	1.2 X 10 ¹⁴	6.10	3.76 X 10 ⁶	
²⁴⁴ Cm	18.1 yr	18.1 yr	3.0 X 10 ¹²	5.80	7.73 X 10 ⁴	
²⁴⁹ Bk	320 days	6.1 X 10 ⁴ yr	8.8 X 10 ⁸	5.40	1.8 X 10 ¹	
²⁵² Cf	2.646 yr	2.731 yr	1.9 X 10 ¹³	6.11	6.0 X 10 ⁵	

The alpha particles emitted by plutonium have an average energy of about 5.2 MeV, and the ones emitted by uranium have an average energy of about 4.7 MeV. Alpha particles in this energy range have a very short range, and they will not escape from even the thinnest plutonium sample cans. However, they can have a tremendous effect on the detected neutron count rate. This is because the flux of alpha particles present in the sample can lead to (α ,n) reactions in low-Z matrix materials that may be present, including oxygen, water, fluorine, etc. Whether the reaction can occur depends on the initial energy of the emitted alpha particle, the reaction Q-value, the required threshold energy, and the Coulomb barrier. These parameters are summarized in Table 5.4 (Ensslin 91a) for the low-Z elements that can undergo (α ,n) reactions.

Table 5.4. Reaction Q-values, threshold energies, and coulomb barriers for the low-Z elements that undergo (α,n) reactions (from Ensslin 91a).

Nucleus	Natural Abundance (%)	Q-Value (MeV)	Threshold Energy (MeV)	Coulomb Barrier (MeV)	Maximum Neutron Energy for 5.2-MeV Alpha
⁴ He	100	-18.99	38.0	1.5	
⁶ Li	7.5	-3.70	6.32	2.1	
⁷ Li	92.5	-2.79	4.38	2.1	1.2
⁹ Be	100	+5.70	0	2.6	10.8
¹⁰ B	19.8	+1.06	0	3.2	5.9
¹¹ B	80.2	+0.16	0	3.2	5.0
¹² C	98.9	-8.51	11.34	3.7	
¹³ C	1.11	+2.22	0	3.7	7.2
¹⁴ N	99.6	-4.73	6.09	4.1	
¹⁵ N	0.4	-6.42	8.13	4.1	
¹⁶ O	99.8	-12.14	15.2	4.7	
¹⁷ O	0.04	+0.59	0	4.6	5.5
¹⁸ O	0.2	-0.70	0.85	4.6	4.2
¹⁹ F	100	-1.95	2.36	5.1	2.9
²⁰ Ne	90.9	-7.22	8.66	5.6	
²¹ Ne	0.3	+2.55	0	5.5	7.6
²² Ne	8.8	-0.48	0.57	5.5	4.5
²³ Na	100	-2.96	3.49	6.0	1.8
²⁴ Mg	79.0	-7.19	8.39	6.4	
²⁵ Mg	10.0	+2.65	0	6.4	7.7
²⁶ Mg	11.0	+0.03	0	6.3	5.0
²⁷ Al	100	-2.64	3.03	6.8	2.2
²⁹ Si	4.7	-1.53	1.74	7.2	3.4
³⁰ Si	3.1	-3.49	3.96	7.2	1.4
³⁷ Cl	24.2	-3.87	4.29	8.3	1.0

If the total neutron emission rate due to (α,n) reactions is N_α , we can define the ratio of (α,n) neutrons to spontaneous fission neutrons by

$$\alpha = \frac{N_\alpha}{N_{sf}} = \frac{N_\alpha}{F v_s} \quad (5-2)$$

For pure plutonium metal samples, $\alpha=0$. For oxides and fluorides, the (α,n) reaction yields are summarized in Table 5.3. From these yields, we can compute α for samples of pure plutonium oxide (with americium in remove gap growth) from the following equation:

$$\alpha = \frac{13400f_{238} + 38.1f_{239} + 141f_{240} + 1.3f_{241} + 2.0f_{242} + 2690f_{Am241}}{1020(2.54f_{238} + f_{240} + 1.69f_{242})} \quad (5-3)$$

The (α,n) yield in other plutonium or uranium compounds, or in samples that contain other low-Z elements mixed in as impurities, can be computed from Eqs. 11.5 through 11.7 in (Ensslin 91a).

Table 5.5 (Ensslin 91a) summarizes thick target (α,n) yields in common elements, and the average energy of the neutrons that are emitted. From Table 5.5 we can see which low-Z elements are most likely to significantly increase the neutron emission rate of the sample.

Table 5.5. Thick target yields from the low-Z elements that can undergo (α,n) reactions (error bars estimated from scatter between different experiments (from Ensslin 91a).			
Element (Natural Isotopic Composition)	Neutron Yield per 10^6 Alphas of Energy 4.7 MeV (^{234}U)	Neutron Yield per 10^6 Alphas of Energy 5.2 MeV	Av. Neutron Energy (MeV) for 5.2 MeV Alpha
Li	0.16 ± 0.04	1.13 ± 0.25	0.3
Be	44 ± 4	65 ± 5	4.2
B	12.4 ± 0.6	17.5 ± 0.4	2.9
C	0.051 ± 0.002	0.078 ± 0.004	4.4
O	0.040 ± 0.001	0.059 ± 0.002	1.9
F	3.1 ± 0.3	5.9 ± 0.6	1.2
Na	0.5 ± 0.5	1.1 ± 0.5	
Mg	0.42 ± 0.03	0.89 ± 0.02	2.7
Al	0.13 ± 0.01	0.41 ± 0.01	1.0
Si	0.028 ± 0.002	0.076 ± 0.003	1.2
Cl	0.01 ± 0.01	0.07 ± 0.04	

Of course, the goal of neutron multiplicity counting is to provide an accurate assay independent of the sample's (α,n) yield and to provide a value for α without other available information. However, we should be aware of the fact that samples with $\alpha > 0$ may have a neutron energy spectrum different from the expected spontaneous fission neutron energy spectrum. Fortunately, for the most common element present, oxygen, the average energy of the (α,n) neutrons is 2.03 MeV, very close to the average of the spontaneous fission neutrons, 1.96 MeV.

D. Definition of Sample Multiplication

This section describes the sample self-multiplication or induced fission process, which can occur with neutrons from either spontaneous fission or (α,n) reactions. When one of these neutrons induces another fission in the sample, a multiplication event has occurred. Neutron-induced fission is the most common multiplication event, but other reactions such as ($n,2n$) can also be present. Some of the neutrons in the sample may be captured without causing the release of any neutrons, as in (n,γ) or (n,p) reactions. Or, neutrons may eventually leak out of the sample without undergoing any interactions. Based on the discussion in (Stewart 91), we can define the following quantities:

- v_i = the average number of neutrons created by induced fission,
- p = probability that a neutron will induce a fission
- p_C = probability that a neutron will be captured without producing any new neutrons
- p_L = probability that a neutron will escape the sample (leakage probability).

If we neglect any neutron-producing reactions other than fission, then $p + p_C + p_L = 1$. A neutron can induce a fission with probability p and disappear with probability $(1-p)$.

The total multiplication M_T is the total number of neutrons that exist in the sample divided by the number of neutrons that were started. If 100 neutrons are started in the sample and an additional 59 are created by multiplication events, $M=1.59$. Only a fraction of the first generation of 100 neutrons produces additional neutrons through multiplication; the others either leak from the sample or are captured without producing neutrons. The same fraction of the second generation produces a third generation, and so on. The number of neutrons in the sample decreases steadily to zero, and the total number of neutrons created by all the multiplication events is 59.

The multiplication factor k relates the number of neutrons in successive generations. If the sample is infinitely large, the multiplication factor is written as k and is defined as the ratio of the number of neutrons in one generation to the number in the previous generation. If the sample is not infinitely large, some neutrons in each generation may leak out of the sample. The multiplication factor for this more practical situation is called k_{eff} , or just “ k ” for brevity. It is defined as the ratio of the number of neutrons produced in one generation to the number either absorbed or leaked in the preceding generation.

The total multiplication M_T can be related to the multiplication factor k , provided that k is less than 1, by adding together all the neutrons in all the generations and summing the series. This process can be expressed quantitatively, with the multiplication factor k given by $p v_i$. For all generations, the sum of the number of neutrons created per initial source neutron is the total multiplication M_T .

$$M_T = \frac{1}{1 - p v_i} = \frac{1}{1 - k}, k < 1 \quad . \quad (5-4)$$

We also define another quantity called the net leakage multiplication M_L . This term reflects the fact that not all of the new neutrons produced by induced fissions will escape from the sample, instead some will be captured within the sample. M_L is always less than or nearly equal to M_T , depending on the value of p . Under the assumption that the probability of neutron capture in the sample without fission is small, which is usually true, the leakage multiplication M_L is approximately given by $(1 - p) M_T$. Then we can use the following approximate relationship for the net leakage multiplication:

$$M = \frac{1 - p}{1 - p v_i} \quad . \quad (5-5)$$

Here we have dropped the subscript L , and for the rest of this report we will just use M for the leakage multiplication. This is the appropriate quantity for neutron multiplicity counting because the leakage multiplication is the measure of the neutrons that leak out of the sample and are available for detection in the counter. For actual samples, v_i , p , and p_C depend on the neutron energy spectrum in the sample, the sample composition, and the sample density. For example, from Table 5.2, the mean value for the induced fission neutron multiplicity $v_{i1} = 2.876$ for thermal neutron induced fission, whereas $v_{i1} = 3.163$ for fast fission neutron (about 2 MeV average energy) induced fission. The probabilities p and p_C also depend on sample geometry and on the reflection of neutrons back into the sample from the well counter. Thus the leakage multiplication M depends on all of these parameters, and the value of M that is of interest to neutron coincidence

counting is the multiplication observed with the sample inside the counter rather than the M of the sample in an unreflected geometry.

Although the leakage multiplication varies from sample to sample and affects the measured coincidence response, there is no direct means of determining M for an unknown sample. It may be calculated by Monte Carlo codes, it may be estimated from the observed doubles to singles ratio (Ensslin 85), or it may be calculated from the observed triples to doubles ratio using the multiplicity equations derived in this chapter. Another way to obtain an estimate for M is from the geometry of the sample. The fission probability p is proportional to the product of the ^{239}Pu -effective density ρ and the mean chord length in the sample (Langner 93). All of these methods will provide a value for the combined M of the sample and detector averaged over the neutron energy spectrum. In practice, it is not always valid to assume that M is constant across the sample. For irregular samples with lumps of plutonium, the average neutron response observed outside the sample may not be a true guide to how much the probability of fission, or the net neutron worth, varies within the sample and how much the correlated neutron response is affected.

Not only does the well counter affect the sample multiplication, but sample multiplication itself affects the coincidence response of the well counter. As the leakage multiplication M increases, the neutron die-away time of the counter increases because the neutrons that induce fissions create a new source of neutrons. When the die-away time changes, the fraction of coincidence events accepted by the coincidence electronics also changes. The magnitude of the effect depends strongly on whether or not the detector well is lined with cadmium. If it is not, thermal neutrons (which are the slowest neutrons and the ones with the highest fission cross section) can readily return to the sample and cause fissions. An expression for the increase in the detector die-away time has been derived by Boehnel for a thermal system with no cadmium liner (Boehnel 75):

$$\tau(M > 1) = \frac{\tau(M = 1)}{1 - p v_i} \quad . \quad (5-6)$$

If the detector well is lined with cadmium, thermal neutrons cannot return to the sample, and the increase in die-away time is small and usually negligible.

Because the ratio of triples to doubles is a strong measure of multiplication, we exploit this effect to determine M in neutron multiplicity counting. The higher source multiplicities for the sample with neutron multiplication produce a higher coincidence gate multiplicity and therefore a higher triples rate. An example is shown in Table 5.6. The emitted neutron multiplicity distribution is shown for spontaneous fission in ^{240}Pu , and for spontaneous fission of ^{240}Pu plus induced fission in ^{239}Pu with a multiplication of 1.04 (i.e., the induced fissions increase the neutron output by 4%—a typical value for a few hundred grams of plutonium oxide). We observe that the emitted neutron distribution is shifted towards higher multiplicities, which increase the doubles (v_2) more than the singles (v_1), and the triples (v_3) much more than the doubles.

Table 5.6. Example of the change in the neutron multiplicity distribution at M=1.04.		
P(v)	²⁴⁰ Pu spontaneous fission only	²⁴⁰ Pu spont. fiss. + ²³⁹ Pu induced fission: (M = 1.04)
0	0.066	0.066
1	0.232	0.227
2	0.329	0.318
3	0.251	0.242
4	0.102	0.101
5	0.018	0.025
6	0.002	0.010
7	0	0.005
8	0	0.003
9	0	0.002
10	0	0.001
v_1	2.156	2.240
v_2	3.825	4.712
v_3	5.336	10.362

E. Assumptions in the Equations

The equations given later in this part of the guide are based on some important assumptions and mathematical models about the process of neutron emission and detection. To the extent that the theoretical model matches the plutonium samples, the measured singles, doubles, and triples rates provide an exact solution for the effective ²⁴⁰Pu mass, the multiplication M, and the (α ,n) fraction α . To the extent that the model is not a perfect match, we can expect to encounter some biases or limitations in the multiplicity technique. In this regard, the following assumptions are important to remember:

(1) It is assumed that all induced fission neutrons are emitted simultaneously with the original spontaneous fission or (α ,n) reaction, independent of the length of the fission chain. This assumption is called the superfission concept (Boehnel 85). Because of the very short time scale of the fission process relative to the neutron die-away time in the well counter, this is a good assumption except for those neutrons that re-enter the sample from the counter (reflected neutrons) and induce fissions, as discussed in the previous section.

(2) It is assumed that the neutron detector efficiency and the probability of fission are uniform over the sample volume. This assumption is called the “point model” because it is equivalent to assuming that all neutrons are emitted at one point in the sample. The assumption of constant efficiency is not always valid, but is becoming easier to achieve with the new multiplicity counters that are designed to have a flat efficiency profile across the sample volume. The assumption of constant fission probability only works for samples that are dilute or thin with respect to the neutron mean free path, such as oxides.

(3) It is assumed that (α ,n) neutrons and spontaneous fission neutrons have the same energy spectrum, so that the detection efficiency ϵ , the fission probability p, and the induced-fission multiplicity v_i are the same for both neutron sources. This assumption is not valid for most

(α, n) neutron sources such as those from fluorine, magnesium, lithium, and carbon, although for plutonium oxide the (α, n) and spontaneous fission neutrons have similar mean energies but different spectrum shapes. Boehnel (85) has outlined the process for re-deriving the multiplicity distribution moments if ϵ and p are different, but the resulting equations are very complex. In practice, the best approach is to design the multiplicity counter so that its detection efficiency is as nearly energy independent as possible, as was discussed in Part II.

(4) It is assumed that neutron capture without fission is negligible, so that Eq. 5.5 can be used for the net leakage multiplication M .

(5) It is assumed that the distributions of neutron multiplicity and neutron energy emitted in each fission are not correlated. In other words, if the number of neutrons emitted in a fission is above average, will the mean neutron energy be below average? The available evidence indicates that the mean neutron emission energy is approximately constant and that the number of neutrons increases with the available energy (Gavron 74).

(6) It is assumed that the neutron die-away time in the sample/detector combination is well approximated by a single exponential time constant. This is not always the case, especially for drum-sized multiplicity counters, which often appear to have two observable decay constants. This effect is not serious, and can be compensated for during the calibration process. The equations required to adjust the observed double and triple coincidences for a dual decay mode die-away time are given by Pickrell (97b).

F . Definitions of the Multiplicity Distributions and Moments

Keeping track of the different multiplicity distributions used for data analysis is not for the faint-hearted! The following list defines all of the distributions used later. Note that we take pains to define different distributions depending on whether the trigger event is one of the detected neutrons or is just chosen randomly or periodically, whether the trigger event is a fission neutron or not and whether the neutrons that follow the trigger are correlated to it or not.

$P(v)$ = Distribution of neutrons emitted in a fission. If (α, n) neutrons are defined as fissions with $v=1$, then they can be included in $P(v)$.

$D(n)$ = Distribution of detected neutrons. If the neutron detection efficiency $\epsilon=1$, then $D(n)$ would be equal to $P(v)$.

$f(i)$ = Distribution of signal-triggered measured events, i.e., neutrons that are detected and counted in the gate interval following any trigger. This is the measured foreground, or R+A distribution. This distribution is called $P(i)$ in the neutron coincidence counter (NCC) software code and in (Krick 85 and 93).

$g(i)$ = Distribution of fission-signal-triggered measured events, i.e., neutrons that would be detected and counted in the gate interval following a trigger that came from a fission event.

$b(i)$ = Distribution of randomly-triggered measured events, i.e., neutrons that are detected and counted in the gate interval following a random or periodic trigger. This is the measured background or A distribution. This distribution is called $Q(i)$ in the NCC software code and in (Krick 85 and 93).

$r(i)$ = Distribution of correlated neutrons that are detected and counted following a signal trigger.

$s(i)$ = Distribution of correlated neutrons that are detected and counted following a random or periodic trigger.

We will define all distributions to be normalized to 1, as in Eq. (5.1).

The same statistical information can be described equivalently using either a probability distribution or the factorial moments of that distribution. Analytical expressions for the factorial moments v_k of the neutron multiplicity distribution emitted by a multiplying sample have been derived (Boehnel 85 and Hage 85). We will work with the first three factorial moments of the distributions, which are given by:

$$v_1 = \sum_{v=1}^{\max} vP(v) \quad , \quad (5-7)$$

$$v_2 = \sum_{v=2}^{\max} v(v-1)P(v) \quad , \quad (5-8)$$

$$v_3 = \sum_{v=3}^{\max} v(v-1)(v-2)P(v) \quad , \quad (5-9)$$

where $P(v)$ is the probability of obtaining an event with multiplicity v . The general expression for a factorial moment is the following:

$$v_k = \sum_{v=k}^{\max} \frac{v!}{(v-k)!} P(v) \quad . \quad (5-10)$$

It is also common to work with reduced factorial moments, which add a term $k!$ to the denominator which comes from combinatorial analysis and corrects for the multiple counting effects that can occur by considering all possible combinations of identical neutrons. Multiplicity analysis can be done either way, but in the derivations below we will usually work with the regular factorial moments.

(We note in passing that there is an alternative approach to moments analysis. Multiplet analysis, as developed by Bondar (96) and Dierckx and Hage (NSE 85, 1983), uses separate equations for the emitted and measured events for each correlated multiplet $r(i)$ and $s(i)$ —the number of events of multiplicity i that are measured. We will use moments analysis instead because the moments yield solutions for F , M , and α in closed form, whereas the multiplet approach requires an iterative procedure. The moments approach also yields equations that are linear in F).

G. The Measured Foreground and Background Multiplicity Distributions

We need to extract values for S , D , and T from the multiplicity shift register covered in Part IV of this guide. As described there, this electronics package measures the detected and counted foreground multiplicity distribution in the R+A gate, and the background distribution in the A gate. The measured foreground distribution is called $f(i)$ or $P(i)$, and the background distribution is called $b(i)$ or $Q(i)$. As the designation R+A implies, the foreground distribution is actually a combination of the real correlated multiplicity distribution R mixed with the accidental multiplicity distribution A . Thus the observed distributions can be very complex, as illustrated in the examples below.

Table 5.7 (same as Table 4.1) lists the multiplicity distribution for a real 60-g plutonium oxide sample measured in a multiplicity counter with roughly 56% neutron detection efficiency. Table 5.8 lists the multiplicity distribution from a 3.8-kg plutonium metal sample, and Fig. 5.2 is a histogram of that distribution. These multiplicity distributions describe the probabilities of counting events of a given multiplicity in the R+A and A gates. The higher the singles rate, the longer the distributions will be. The average multiplicity of the background distribution depends on this rate and on the coincidence gate width and is given by SG.

Table 5.7. Neutron multiplicity distribution from a real 60-g plutonium oxide sample measured in a multiplicity counter with roughly 56% neutron detection efficiency.		
	R+A	A
0	26804360	29731130
1	8187530	6222207
2	1772831	1016603
3	325270	157224
4	53449	22387
5	8231	3093
6	1237	402
7	183	42
8	30	8
9	2	1
10	0	0
11	0	0
12	0	0

Table 5.8. Neutron multiplicity distribution from a 3.8-kg plutonium metal sample measured in a multiplicity counter with roughly 56% neutron detection efficiency.

	R+A	A		R+A	A		R+A	A
0	1347503	2342585	23	377424	182845	45	71	26
1	5548119	8741608	24	261832	123318	46	44	14
2	12594691	18155789	25	180734	82901	47	18	6
3	20880464	27689521	26	125053	55343	48	20	3
4	28286672	34717294	27	86088	37277	49	19	6
5	33227391	37930829	28	58758	24837	50	16	4
6	35076936	37377198	29	40354	16862	51	10	1
7	34113057	34051848	30	27484	11242	52	4	1
8	31095848	29187102	31	18999	7693	53	10	2
9	26937850	23810063	32	13004	5203	54	11	2
10	22383998	18699047	33	8553	3265	55	3	1
11	17975050	14233768	34	5759	2253	56	5	0
12	14036174	10551271	35	3995	1522	57	2	0
13	10708296	7661030	36	2612	988	58	3	0
14	8021716	5469190	37	1860	714	59	0	0
15	5913582	3856263	38	1291	417	60	1	1
16	4308170	2691844	39	912	313	61	0	0
17	3104553	1858200	40	602	205	62	1	0
18	2216044	1273803	41	406	122	63	1	0
19	1567713	869397	42	237	74	64	0	0
20	1107785	592481	43	154	49			
21	776274	398955	44	112	28			
22	541207	270021						

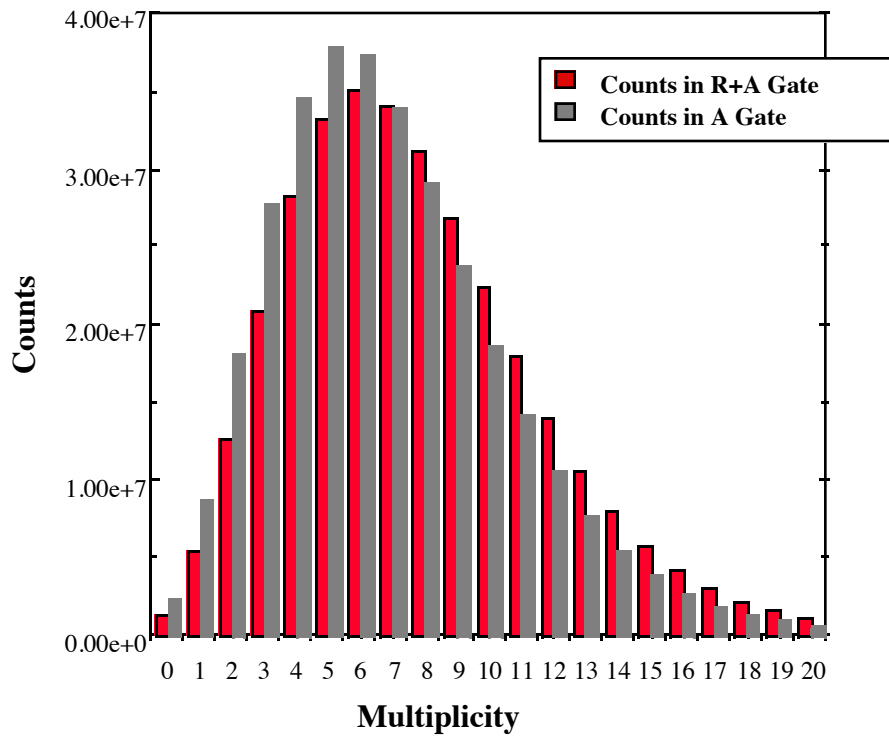

Fig. 5.2. Multiplicity distribution for a 3.8-kg plutonium metal sample measured in a 56% efficient neutron multiplicity counter.

Figures 5.3 and 5.4 compare the multiplicity distributions for an AmLi neutron source and for a large ^{252}Cf neutron source. Because the AmLi source emits only single, random neutrons from (α, n) reactions, the R+A and A distributions in Fig. 5.3 are identical. In Fig. 5.4, we see that the presence of real or correlated neutrons from californium shifts the R+A distribution to higher multiplicities than the A distribution, but that the difference is small.

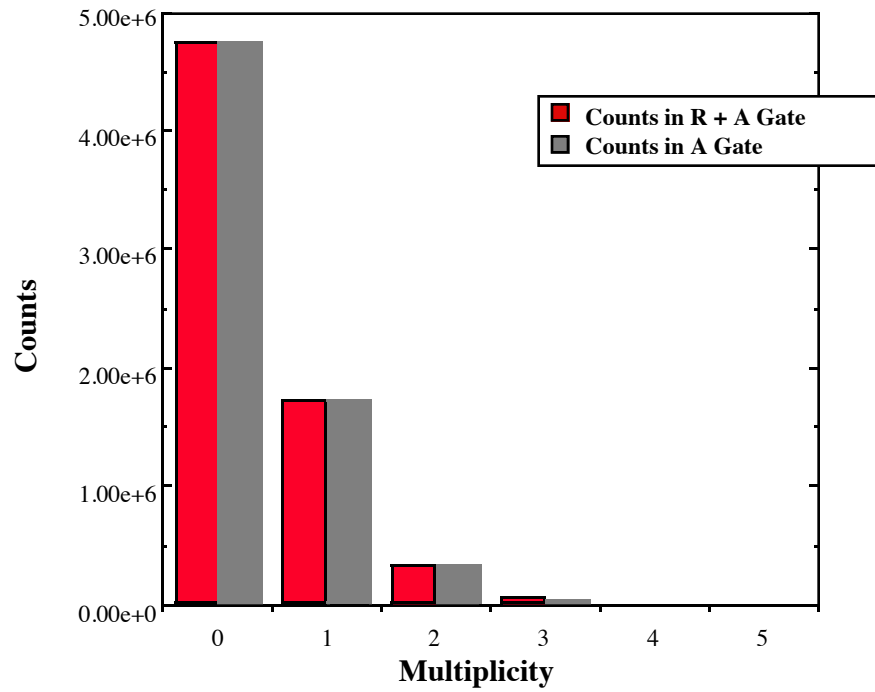

Fig. 5.3. Multiplicity distribution for an AmLi random neutron source measured in a 56% efficient neutron multiplicity counter.

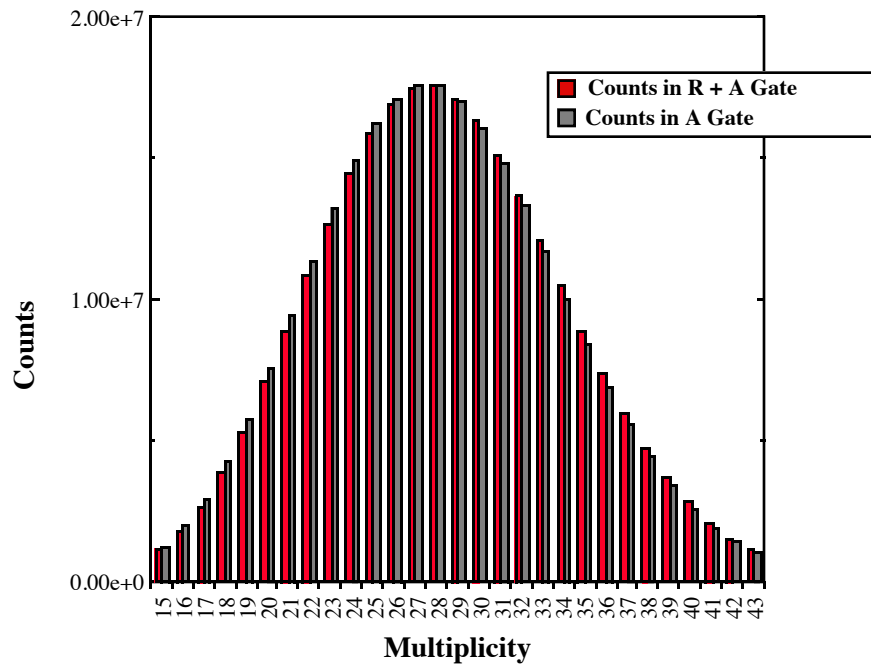

Fig. 5.4. Multiplicity distribution for a large ²⁵²Cf neutron source measured in a 56% efficient neutron multiplicity counter.

H. Extraction of the Correlated Multiplicity Distributions

In Section G we saw that the foreground distribution is actually a mixture of the real correlated multiplicity distribution R and the accidental multiplicity distribution A. Also, it's true that the measured foreground distribution is produced by trigger events that can be fission events or background events. This means that an unfolding process is needed to extract the information that we really want—the distribution $r(i)$ of correlated neutrons that are detected and counted following a fission trigger.

First, we correct for the presence of accidental triggers. The total trigger rate is the singles rate $S = F\varepsilon V + S_{\text{bkg}}$, where the fission trigger rate is $F\varepsilon V$. Then the measured foreground moments are

$$f_k = \frac{F\varepsilon V}{S} g_k + \left[1 - \frac{F\varepsilon V}{S}\right] b_k \quad , \quad (5-11)$$

where g_k are the moments of the distribution $g(i)$ of measured events that follow a fission trigger.

Second, to correct for accidental coincidences, note that $g(i)$ is a convolution of $r(i)$ and $b(i)$:

$$\begin{aligned} g(0) &= r(0)b(0), \\ g(1) &= r(0)b(1) + r(1)b(0), \\ g(2) &= r(0)b(2) + r(1)b(1) + r(2)b(0), \text{ etc.} \end{aligned}$$

If we sum up these distributions in moments form, we obtain the relationship

$$g_k = \sum_{j=0}^k \binom{k}{j} r_j b_{k-j} \quad . \quad (5-12)$$

Combining Eqs. 5.11 and 5.12 yields the following equation for the moments r_k (with $r_0 = 1$ because the distribution is normalized to 1):

$$f_k - b_k = \frac{F\varepsilon V}{S} \left[\sum_{j=0}^k \binom{k}{j} r_j b_{k-j} - b_k \right] \quad . \quad (5-13)$$

The first three correlated moments r_k , multiplied by the sample trigger rate $(S - S_{\text{bkg}})$, are the singles, doubles, and triples that we are looking for:

$$\text{Singles} = (S - S_{\text{bkg}}) r_0 = S \quad (5-14)$$

$$\text{Doubles} = (S - S_{\text{bkg}}) r_1 = S(f_1 - b_1) \quad (5-15)$$

$$\text{Triples} = (S - S_{\text{bkg}}) r_2 / 2! = S(f_2 - b_2 - 2b_1(f_1 - b_1)) / 2 \quad (5-16)$$

Note that the doubles are the difference between the first moment of the multiplicity distribution in the foreground (R+A) gate and the first moment of the multiplicity distribution in the background

(A) gate, as expected from the way that the shift register operates. The triples equation is not so intuitively obvious because of the cross terms.

The procedure for obtaining the moments s_k of the randomly triggered correlated distribution is similar, except that there is no need to correct $b(i)$ for accidental triggers. Assume that the total trigger rate is still S , so that there is one delayed random trigger for every foreground trigger. The expression for the moments s_k is given by Hage (85):

$$b_k = \sum_{j=0}^{k-1} \binom{k-1}{j} s_{k-j} b_j \quad . \quad (5-17)$$

The first three moments are

$$\begin{aligned} s_0 &= 1, \\ s_1 &= b_1, \\ s_2 &= b_2 - b_1^2. \\ s_3 &= b_3 - 3 b_1 b_2 + 2 b_1^3 \quad . \end{aligned} \quad (5-18)$$

The first moment of the measured background distribution is $b_1 = SG$.

It is not as commonly known, but it is also possible to write down equations for singles, doubles, and triples using only the background-triggered moments, as in the Feynman variance approach (Robba 83). For completeness, these are listed below:

$$Singles = S s_0 = S \quad (5-19)$$

$$Doubles = \frac{SE_1}{G\epsilon W_2} (b_2 - b_1^2) \quad (5-20)$$

$$Triples = \frac{SE_2}{G\epsilon^2 W_3} (b_3 - 3b_1 b_2 + 2b_1^3) \quad (5-21)$$

Here, ϵ is the neutron detection efficiency, and the coincidence gate fractions E_k and W_k are defined in Section K below.

I. The Emitted Fission Multiplicity Distribution

For samples that emit both spontaneous fission and (α,n) neutrons, we can define a combined multiplicity distribution by considering (α,n) reactions as a fission source that always emits one neutron. The combined distribution of both (α,n) and spontaneous fission neutrons is given by

$$P(\nu) = \frac{\alpha \nu_s \delta_{1\nu} + P_{sf}(\nu)}{1 + \alpha \nu_s} \quad , \quad (5-22)$$

where $\delta_{1\nu} = 1$ if $\nu=1$ and 0 otherwise.

With this definition of the emitted multiplicity distribution for actual samples, the first three factorial moments are given by

$$v_1 = Mv_{s1}(1 + \alpha) \quad , \quad (5-23)$$

$$v_2 = M^2 \left[v_{s2} + \left(\frac{M-1}{v_{i1}-1} \right) v_{s1}(1 + \alpha)v_{i2} \right] \quad , \text{ and} \quad (5-24)$$

$$v_3 = M^3 \left\{ v_{s3} + \left(\frac{M-1}{v_{i1}-1} \right) [3v_{s2}v_{i2} + v_{s1}(1 + \alpha)v_{i3}] + 3 \left(\frac{M-1}{v_{i1}-1} \right)^2 v_{s1}(1 + \alpha)v_{i2}^2 \right\} \quad . \quad (5-25)$$

These equations were derived independently by Boehnel (85) and Hage (85) based on the point model and other assumptions described in Section E.

J. The Detected Multiplicity Distribution

The actual observed multiplicity distribution and its moments will be less than the emitted moments given in Eqs. 5.23 through 5.25 because the neutron detection efficiency ε of the multiplicity counter will be less than one. In terms of the emitted multiplicity distribution $P(v)$, the detected distribution $D(n)$ is given by

$$D(n) = \sum_{v=n}^{\max} P(v) \binom{v}{n} \varepsilon^n (1 - \varepsilon)^{v-n} \quad . \quad (5-26)$$

The mean of this detected distribution is given by

$$\sum_{n=0}^{\max} nD(n) = \varepsilon v_1 \quad , \quad (5-27)$$

which can be derived using the relationship

$$\sum_{k=0}^n k \binom{n}{k} \varepsilon^k (1 - \varepsilon)^{n-k} = n\varepsilon \quad . \quad (5-28)$$

Note that in Eq. 5.27, ε and v are separable. This important feature is also true for the higher moments, and makes the equations for singles, doubles, and triples that are given below much simpler. However, we are making the point model assumption that the detection efficiency is constant across the sample. Also, we are assuming that the detection efficiency for spontaneous fission and (α, n) neutrons is the same, as discussed in Section E.

K. The Detected and Counted Multiplicity Distribution

This section provides analytical expressions for the multiplicity distribution of events that are detected, and then also counted within the coincidence gate width G . Specifically, we want the moments r_k and s_k of the correlated events that are detected and counted. This section is based on derivations by Hage (85) and Dytlewski (Ensslin 90a).

To obtain expressions for the signal-triggered correlated moments r_k , suppose that a burst of n neutrons is detected, of which the first is the signal trigger. Because the gate width is finite,

only a fraction of all coincidences can be detected. For a fission that occurs at $t=0$, the time distribution of detected neutrons is $f(t)$. Ideally, this is the Rossi- α distribution illustrated in Fig. 4.5. A simplified schematic is given in Fig. 5.5. Here the counting interval is the gate length G , and the predelay is PD .

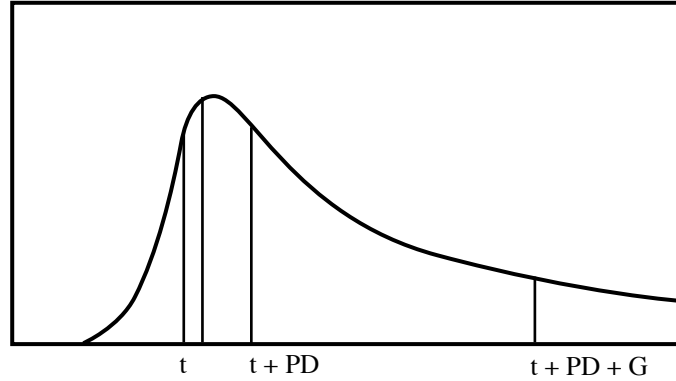

Fig. 5.5. Simplified time distribution for signal-triggered events.

The probability of capturing one of the n neutrons in a time interval between t and $t+dt$ is $nf(t)dt$. This is the probability of obtaining a first or trigger event. The probability that a following neutron, one of the remaining $(n-1)$ detected neutrons, lies in the counting interval $(t+PD)$ to $(t+PD+G)$ is given by the integral

$$p_t = \int_{t+PD}^{t+PD+G} f(s) ds \quad . \quad (5-29)$$

Integrating over all time t , the probability of obtaining a trigger and then counting i of the $(n-1)$ following neutrons in the gate is

$$p_{t,i} = n \int_0^{\infty} f(t) \binom{n-1}{i} p_t^i (1-p_t)^{n-1-i} dt \quad . \quad (5-30)$$

Summing over all possible numbers of detected neutrons n [the maximum i is $(n-1)$, or n ranges from $(i+1)$ to a maximum N], the total probability of counting i neutrons in the gate after the trigger is

$$r(i) = \sum_{n=i+1}^N \frac{nD(n)}{\epsilon V} \int_0^{\infty} f(t) \binom{n-1}{i} p_t^i (1-p_t)^{n-1-i} dt \quad . \quad (5-31)$$

The probability $r(i)$ is the signal-triggered correlated multiplicity distribution defined in Section F. The normalization factor ϵV is obtained from $r_0 = 1$ and Eq. 5-27. Using the above equations, and Eqs. 5-26 and 5-28, we can derive the following expression for the first moment r_1 :

$$r_1 = \sum_{i=1}^{N-1} i r(i) = \frac{\epsilon^2 V_2}{\epsilon V} \int_0^{\infty} f(t) \left\{ \int_{t+PD}^{t+PD+G} f(s) ds \right\} dt \quad . \quad (5-32)$$

The second correlated moment r_2 is given by a similar equation:

$$r_2 = \sum_{i=1}^{N-1} i(i-1)r(i) = \frac{\varepsilon^3 v_3}{\varepsilon v} \int_0^\infty f(t) \left\{ \int_{t+PD}^{t+PD+G} f(s) ds \right\}^2 dt \quad . \quad (5-33)$$

Integrating Eqs. 5-32 and 5-33, the correlated moments become

$$r_1 = \frac{v_2}{v} E_1 \quad , \quad (5-34)$$

$$r_2 = \frac{v_3}{v} E_2 \quad . \quad (5-35)$$

E_1 and E_2 represent the fractions of the signal-triggered correlated events that are detected and counted:

$$E_n = \frac{(\varepsilon f)^n}{n+1} \quad . \quad (5-36)$$

The factor $(n+1)$ in the denominator of Eq. 5-36 results from the ordering of the time integrals following the trigger. The same factors appear in the shift register response equations and are thought of as part of the reduced factorial moments of v and are considered to correct for double counting of coincident events.

For a single exponential detector die-away with time constant τ , the gate fraction f is given by

$$f = e^{-PD/\tau} (1 - e^{-G/\tau}) \quad . \quad (5-37)$$

If the well counter does not have a single die-away time, but has a known efficiency, the gate fraction can also be obtained experimentally with a californium source or a small non-multiplying plutonium source, as described under the calibration procedure in Part VI, Section M.

Similar analytical expressions can be derived for the randomly-triggered correlated moments s_k . Suppose that a fission burst with n detected neutrons occurs at $t=0$. As illustrated in Fig. 5.6, there will be a contribution to the correlated response if a randomly-triggered gate starts (a) between $t=-G$ and $t=0$ or (b) between $t=0$ and $t=\infty$. The probability that a randomly-triggered gate will occur between t and $t+dt$ is Sdt . The probability that one of the n detected neutrons lies in the counting interval defined by the gate is

$$q_t = \int_t^{t+G} f(s) ds \quad , \quad (5-38)$$

for time interval (b). For time interval (a) the lower limit of integration is $s=0$ rather than $s=t$. Integrating over all time intervals in (a) and (b), and summing over all possible numbers of detected neutrons n , the total probability of counting i neutrons in the randomly-triggered gate is

$$s(i) = \sum_{n=i}^N \frac{D(n)}{\epsilon v} \int_{-G}^{\infty} S \binom{n}{i} q_t^i (1 - q_t)^{n-i} dt \quad . \quad (5-39)$$

The normalization factor is again ϵv . The derivation of the first moment s_1 is similar to the derivation of r_1 :

$$s_1 = \sum_{n=i}^N \frac{nD(n)}{\epsilon v} \left\{ \int_{-G}^0 S dt \int_0^{t+G} q_t ds + \int_0^{\infty} S dt \int_t^{t+G} q_t ds \right\} = SG \quad . \quad (5-40)$$

The derivation of the second moment s_2 is similar, but involves the second moment of $D(n)$ and the square of the integrals involving $q_t ds$:

$$s_2 = SG \frac{\epsilon v_2}{v} \left[1 - \frac{\tau}{G} (1 - e^{-G/\tau}) \right] \quad . \quad (5-41)$$

The general relationship between the randomly-triggered moments s_k and the signal-triggered moments r_k is derived in Cifarelli (86):

$$s_k = SG \frac{W_k}{f^{k-1}/k} r_{k-1} \quad . \quad (5-42)$$

The time integral f is given by Eq 5-37 for a single exponential die-away time. The coefficients W_k represent the fractions of the randomly-triggered correlated events that are counted and are given by (Cifarelli 86):

$$W_k = \sum_{j=0}^{k-1} \binom{k-1}{j} (-1)^j \frac{1 - e - jG/\tau}{jG/\tau} \quad . \quad (5-43)$$

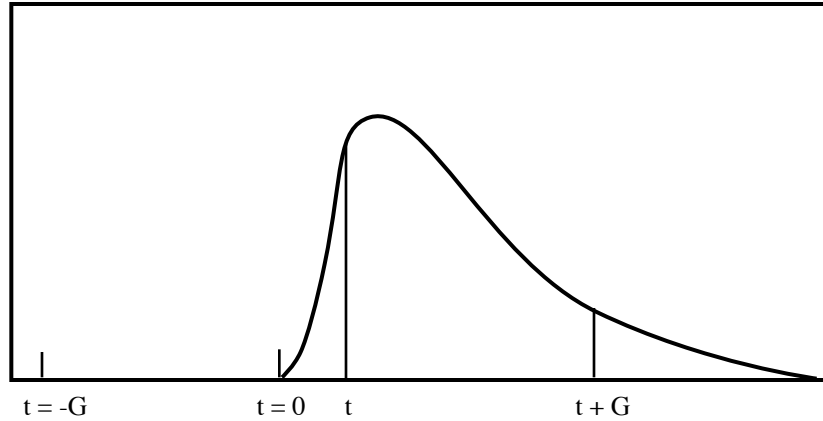

Fig. 5.6. Simplified time distribution for random-triggered events.

L. Analytical Definition of Singles, Doubles, and Triples

We can now define the measured singles, doubles, and triples rates from an actual sample in terms of three equations for the moments of the emitted and counted multiplicity distribution. Using Eqs. 5-14 through 5-16, Eqs. 5-34 through 5-36, and then Eqs. 5-23 through 5-25, and the relationship $(S-S_{\text{bkg}})=F\varepsilon v$, we obtain

$$S = F\varepsilon M v_{s1}(1 + \alpha) \quad , \quad (5-44)$$

$$D = \frac{F\varepsilon^2 f_d M^2}{2} \left[v_{s2} + \left(\frac{M-1}{v_{i1}-1} \right) v_{s1}(1 + \alpha)v_{i2} \right] \quad , \text{ and} \quad (5-45)$$

$$T = \frac{F\varepsilon^3 f_t M^3}{6} \left\{ v_{s3} + \left(\frac{M-1}{v_{i1}-1} \right) \left[3v_{s2}v_{i2} + v_{s1}(1 + \alpha)v_{i3} \right] + 3 \left(\frac{M-1}{v_{i1}-1} \right)^2 v_{s1}(1 + \alpha)v_{i2}^2 \right\} \quad . \quad (5-46)$$

To summarize the variables used,

F = spontaneous fission rate, 473 fission/s-g ^{240}Pu , so that m_{240} = effective ^{240}Pu mass,

ε = neutron detection efficiency,

M = neutron leakage multiplication,

α = (α, n) to spontaneous fission neutron ratio,

f_d = doubles gate fraction,

f_t = triples gate fraction,

v_{s1}, v_{s2}, v_{s3} = first, second, and third reduced moments of the spontaneous fission neutron distribution,

v_{i1}, v_{i2}, v_{i3} = first, second, and third reduced moments of the induced fission neutron distribution.

The effective ^{240}Pu mass is that mass of ^{240}Pu that would give the same double coincidence response as that obtained from all the even isotopes in the actual sample:

$$^{240}\text{Pu}_{\text{eff}} = 2.52^{238}\text{Pu} + ^{240}\text{Pu} + 1.68^{242}\text{Pu} \quad . \quad (5-47)$$

Note that some detected neutrons will not be counted inside the coincidence counting gate interval G . This is reflected in the “gate fractions” f_d and f_t . For a single exponential die-away time, the doubles gate fraction f_d is just f , and the triples gate fraction f_t is f^2 , where f is given by Eq. 5-37. In addition, there will be some single, double, and triple background counts due to room background. These are called S_{bkg} , D_{bkg} , and T_{bkg} , but are not included in the equations above.

The singles neutron rate is the first moment of the detected neutron distribution and is simply the sum of all the single neutrons detected, including spontaneous fission, induced fission,

and (α, n) neutrons. Once background neutrons S_{bkg} are added to this, S is equivalent to the sum over all trigger events, either foreground or background (both are the same).

The double coincidence rate is defined as the second moment of the detected and counted neutron multiplicity distribution, divided by $2!$ to correct for double counting (i.e., a coincidence between events 1 and 2 is not considered distinct from a coincidence between events 2 and 1). This definition of the double coincidence rate is not the only possible definition, but it is the one appropriate for a circuit like the shift register, described in Part IV above, that collects all possible pairs between events in a deadtime-free manner. In Eq. 5-45 above, we can also see the three sources of double coincidences: the first term is spontaneous fission, the second term is induced fissions caused by multiplication of spontaneous fission neutrons, and the third term, proportional to α , is induced fissions due to multiplication of (α, n) neutrons.

The triple coincidence rate is defined as the third moment of the detected and counted neutron multiplicity distribution, divided by $3!$ to correct for the six possible combinations for a triple event. It is not so simple to visualize all of the terms in Eq. 5-46, because there are a number of two-step processes that can lead to triple coincidences.

M. Final Solution for Sample Mass, Multiplication, α

Now that we have Eqs. 5-44 through 5-46 that relate singles, doubles, and triples to the unknown sample parameters, and Eqs. 5-14 through 5-16 to obtain singles, doubles, and triples from the multiplicity shift register, we have all the relationships needed for multiplicity analysis. For measurements of large mass items in small containers, we can usually consider the neutron detection efficiency ε to be a known parameter obtained from careful measurement of a californium reference source. Then we can solve Eqs. 5-44 through 5-46 for sample ^{240}Pu -effective mass m_{240} , sample (α, n) reaction rate α , and sample self-multiplication M . The solution for M is obtained first by solving the following cubic equation:

$$a + bM + cM^2 + M^3 = 0 \quad , \quad (5-48)$$

where the coefficients are functions of S , D , and T :

$$a = \frac{-6Tv_{s2}(v_{i1} - 1)}{\varepsilon^2 f_t S(v_{s2}v_{i3} - v_{s3}v_{i2})} \quad , \quad (5-49)$$

$$b = \frac{2D[v_{s3}(v_{i1} - 1) - 3v_{s2}v_{i2}]}{\varepsilon f_d S(v_{s2}v_{i3} - v_{s3}v_{i2})} \quad , \text{ and} \quad (5-50)$$

$$c = \frac{6Dv_{s2}v_{i2}}{\varepsilon f_d S(v_{s2}v_{i3} - v_{s3}v_{i2})} - 1 \quad . \quad (5-51)$$

Once M is determined, then the sample fission rate F is given by

$$F = \frac{\left[\frac{2D}{\varepsilon f_d} - \frac{M(M-1)v_{i2}S}{v_{i1} - 1} \right]}{\varepsilon M^2 v_{s2}} \quad . \quad (5-52)$$

The second term in the numerator of Eq. 5-52 represents the effect of sample self-interrogation due to induced fission, which must be subtracted from the emitted doubles to obtain the spontaneous fission rate. Once F is obtained, the sample's ^{240}Pu -effective mass m_{240} is given by

$$m_{240} = \frac{F}{(473 \text{ fissions/s} - gm)} \quad . \quad (5-53)$$

Also, the sample's (α, n) reaction rate α is given by

$$\alpha = \frac{S}{F \epsilon v_{s1} M} - 1 \quad . \quad (5-54)$$

N . Final Solution for Sample Mass, Detector Efficiency, α

For measurements of low plutonium mass items in large containers, such as waste drums, the neutron detection efficiency ϵ may vary from item to item. This is because matrix materials in the large waste containers can significantly affect the outgoing neutron energy spectrum. But in this situation, it may be a good approximation to assume that sample self-multiplication M equals 1. Then M can be considered a known parameter, and we can solve Eqs. 5-44 through 5-46 for sample ^{240}Pu -effective mass m_{240} , sample (α, n) reaction rate α , and neutron detection efficiency ϵ . The multiplicity data analysis algorithms needed to determine other combinations of three sample parameters were first derived in Cifarelli (86). For this case, we first use the measured values for S , D , and T to obtain α :

$$\alpha = \frac{3STf_d^2 v_{s2}^2}{2D^2 f_t v_{s1} v_{s3}} - 1 \quad . \quad (5-55)$$

Then the sample fission rate is given by

$$F = \frac{S^2 f_d v_{s2}}{2D v_{s1}^2 (1 + \alpha)^2} \quad , \quad (5-56)$$

and the neutron detection efficiency is given by

$$\epsilon = \frac{S}{F v_{s1} (1 + \alpha)} \quad . \quad (5-57)$$

VI. Multiplicity Counter Operating Procedures

A. Hardware Installation and Setup

Hardware installation of a neutron multiplicity counter is the same as for a conventional neutron coincidence counter. Floor space requirements may be slightly greater because the extra rings of ^3He tubes make the counter larger. A low-humidity environment is desirable because the desiccant in the junction box will last longer. A low ambient neutron background is also better, because the outer rings of ^3He tubes may not be fully shielded.

Depending on the multiplicity electronics packaged being used, it may be necessary to provide additional electronics modules. The Los Alamos MSR4 and the Canberra 2150 are Nuclear Instrument Modules that are operated in a powered NIM bin. External or additional +5V or HV power supplies may be needed. An IBM-type personal computer is required to run the neutron software analysis package (see Section C below). Then, the signal and power cables between the multiplicity counter and the multiplicity module need to be connected, and also the serial cable from the computer to the multiplicity module.

B. Overview of the NCC Code

The Windows NCC Code (Harker 96) was developed at Los Alamos National Laboratory as a general-purpose neutron coincidence counting program for DOE facilities. It was originally intended for IBM-type personal computers running Microsoft Windows 3.1. It now also runs under Windows 95 and Windows NT. The code includes data collection and analysis algorithms for passive coincidence counting by several different algorithms, passive multiplicity counting, active coincidence counting, active minus passive coincidence counting, and active multiplicity counting. (Active multiplicity presently determines the neutron multiplication of a uranium item, but does not determine the uranium mass.) Release version 1.1 of the code was disseminated to DOE facilities in 1997 under Office of Safeguards and Security (OSS) funding as a standardized neutron coincidence software package that would provide consistent, auditable analysis algorithms. Technology transfer of the code to Canberra Industries, National Nuclear Corporation, and Aquila Technologies has also been carried out. Canberra presently offers a commercial Neutron Analysis Software package (NAS) based on the NCC code that runs under OS-2.

The Windows NCC code includes startup and file transfer, parameter editing, calibration, data acquisition, and data review menus (Harker 96). The code provides computer control of the multiplicity electronics, all of the calculations necessary to do multiplicity analysis including background and deadtime corrections, calculations of moments from R+A and A distributions, outlier testing to filter cosmic-ray events, corrections for multiplication, and statistical error analysis based on population statistics. A number of measurement control options are included for quality control tests. Calibration curves can be developed from within the code using the built-in Deming least squares fitting program, although this feature is not used for multiplicity calibration.

All measurement results are stored in both database and text files. Database files can be saved and restored for transfer between computers, and individual measurement files can be deleted from the database. Measurement data and results can be called up for review and printed out at any time. Assay results, or singles, doubles, and triples data, can be plotted from a data file. Assay results can be individually selected and output in comma-separated variable form for input to spreadsheet programs such as Microsoft Excel. The operating procedures described in the rest of

this part of the guide will be based on the NCC code. A modification and extension of the NCC code, called the International Neutron Coincidence Counting (INCC) program, has been developed and may in the future be merged with the NCC code (Krick 98).

C. Software Installation and Setup

The minimum system requirements for use of the NCC code are an IBM-type personal computer with the following capabilities (Harker 96):

1. 33 MHz 486 processor,
2. 8 Mbytes Random Access Memory (RAM),
3. 100 Mbytes Fixed Disk,
4. 1.44 Mbytes Floppy Disk,
5. One serial port unless using add-a-source, then two serial ports,
6. Mouse, and
7. Microsoft Windows 3.1, Windows 95, or Windows NT.

To install the NCC Windows software under Windows 3.1, turn on the computer, and type win(enter) from the DOS prompt to get into the Windows operating system. Insert the Windows NCC install disk in drive A. Under the Program Manager, select File/Run. Type a:install(enter) in the Run dialog box.

When the install procedure has completed, double click on the NCC icon which will be in the NCC group. The program should start up, and display the welcome screen. Type (enter) and the main menu will be displayed. When the program is started you will be warned if the hard disk is more than 90% full. If you see this warning, you need to free up some disk space, possibly by deleting some old measurements. If the hard disk becomes 95% full, measurement data acquisition will be disabled. The installation procedure for Windows NCC will overwrite any existing versions of the code and its database. The installation disk can be modified so that a database containing previously entered values such as detector and calibration parameters will be automatically loaded when the software is installed (Harker 96).

D. Detector Parameter Setup

Once the NCC Windows code is loaded, select "Password" under "File" and enter the password to display all menu options. The code is provided with the default password "carte." For the first time setup of the code for multiplicity analysis, there are a number of detector, data collection, and data analysis parameters that need to be set. Under the Edit menu, the user can select the item types to be measured, the analysis methods to be used, and the desired data display and archiving options. The initial background values for the singles, doubles and triples rates should be set to zero, and the initial normalization constant should be set to 1. The user should select "QC tests," i.e., turn the quality-control tests on. Additional information on these initial operating procedures will be given in the next few sections.

For the initial detector setup, select "Detector parameters" under "Edit" and enter the needed parameters. Table 6.1 is an example of a list of parameters associated with the Five-Ring Multiplicity Counter described in Part III, Section B. In the "Detector parameter" window, some of the parameters may be grayed out to indicate that they cannot be set from the computer for the type

of electronics that are available. In this case, these parameters are set directly on the electronics package.

Table 6.1. Example of detector parameter list for the Five-Ring Multiplicity Counter.	
Shift Register Type	
Shift Register Serial Port	COM1
Predelay (μs)	3
Gate (μs)	64
HV (V)	1680
Deadtime Coefficient A	$0.12 \times 10^{-6} \text{s}^{-1}$
Deadtime Coefficient B	$0.00 \times 10^{-12} \text{s}^{-2}$
Deadtime Coefficient C	0
Multiplicity Deadtime	35.83 ns
Detector Die-Away Time	49.1 μs
Detection Efficiency	0.533
Doubles Gate Fraction	0.6279
Triples Gate Fraction	0.3582

E. Detector Characterization: Background

This procedure determines the room background singles, doubles, and triples rates that will be subtracted from all multiplicity measurements. The background is measured with all neutron sources removed from the vicinity of the multiplicity counter to a distance of at least 3 m. Under the NCC Windows code, select “Shift register” as the data source. Select “QC tests,” i.e., turn the quality-control tests on. Select “Background” under “Acquire,” and select “Passive” as the well configuration. For this measurement, as for most multiplicity counter measurements, the available count time should be split up into a series of many smaller runs, such as 10 runs of 30 s each for a total count time of 300 s. This will allow the outlier test to reject runs with unusually large double or triple coincidence bursts due to cosmic rays or other interferences. It is also good to observe the R+A and A multiplicity distributions directly to see if there are any unusually high multiplicity values that do not follow a smooth curve. The singles rate should be in the range of 100 to 1000 counts/s (depending on the expected room background), the doubles rate should be on the order of a few counts/s, and the triples rate should be on the order of 0.1 count/s. If they are not, there may be an electronics problem with the system.

F. Detector Characterization: Bias

The purpose of the bias or normalization measurement is to provide a reference measurement to check the multiplicity counter at any future time to ensure that the instrument is working correctly. This is done using a ^{252}Cf reference source that will be readily available in the future. A bias measurement should be part of a daily measurement control program. Also, it should be done during any calibration activities, so that the validity of the calibration can be checked in the future.

Position the californium reference source in a reproducible position at the center of the assay chamber. Select “Rates” under “Acquire.” Measure the source long enough so that the doubles counting statistics error is small. Record the californium source identification, the doubles rate, and the date under “Edit/Normalization.” The NCC code is now set up to do bias tests at any future time with the reference source. The detector stability is tested with a bias measurement under “Acquire/Bias.” Because the detectors are very stable, the normalization constant is normally set to 1 (no correction). If one or more Amptek circuits should fail, but measurements need to be continued, a bias measurement can be made to set the normalization constant to a value much different than 1, and all the measurement results will be corrected appropriately.

G. Detector Characterization: Efficiency

The purpose of this procedure is to determine the neutron detection efficiency of the multiplicity counter from the measured singles rate of a ^{252}Cf source that has a known neutron yield. This step is an excellent diagnostic that tests the total ^3He and Amptek electronics chain. The singles rates from the californium reference source measured in the preceding section is a convenient choice if the californium source strength is known.

A ^{252}Cf source has a half-life ($T_{1/2}$) of 2.645 years, so the expected yield (Y) is

$$Y = Y_0 e^{-(\ln(2)\Delta T/T_{1/2})} \quad , \quad (6-1)$$

where ΔT is the time from the date that the original source strength Y_0 was determined. $\ln(2) = 0.6931$. The source should be placed at a reproducible position in the center of the assay chamber. Select “Rates only” under “Acquire” and measure the source long enough to get good precision. The detector efficiency ε is determined from the singles count rate, with the singles background subtracted:

$$\varepsilon = \frac{S - S_{bkg}}{Y} \quad . \quad (6-2)$$

Note that the efficiency determined with a californium source may be slightly different than the value needed for multiplicity calibration (see Section M below).

H. Detector Characterization: Die-Away Time and Gate Width

This procedure verifies that the detector die-away time is as expected, and that the coincidence gate width G is correctly set for this die-away time. Under the assumption that the multiplicity counter die-away is given by a single exponential, the probability of detecting a neutron in the coincidence gate is proportional to the gate fraction f given by Eq. 5-37. Remeasure the ^{252}Cf reference source that is in the center of the sample cavity, as in Section F or G above, but change the gate length by a factor of 2, say from $64 \mu\text{s}$ to $32 \mu\text{s}$. Select “Rates only” under “Acquire” and measure the source long enough to get good precision on the doubles count rate. From Eq. 5-37, the ratio of the doubles at a gate length of $64 \mu\text{s}$ to the doubles at $32 \mu\text{s}$ (for the same predelay, die-away time τ , and measurement time) is

$$\frac{D_{64}}{D_{32}} = \frac{1 - e^{-64/\tau}}{1 - e^{-32/\tau}} \quad (6-3)$$

Solving this equation for τ gives

$$\tau = \frac{-32\mu s}{\ln\left(\frac{D_{64}}{D_{32}} - 1\right)} \quad (6-4)$$

Some drum-sized multiplicity counters may have more than one significant component to their die-away curves because the distribution of polyethylene and ^3He is not uniform throughout the detector. Therefore, if the calculation of the die-away time is repeated with other gate lengths, a somewhat different die-away time may be obtained.

The “optimum gate length” for a given coincidence counter, the gate length that gives the lowest relative error for coincidence counting, is roughly 1.27τ . This optimum is a very broad and shallow minimum so that setting the gate width to the nearest multiple of 2 is usually sufficient. At high count rates, it may also be beneficial to set the gate width to a smaller value to reduce deadtime effects on the triples count rate.

I. Detector Characterization: Gate Fractions

Because multiplicity counters may have more than one significant component to their die-away curves, the calibration process described in Section M below does not rely directly on the gate fraction f that is determined from the measured die-away time using Eq. 5-37. Instead, we empirically determine the actual fractions of the doubles and triples that are counted within the gate width G . These doubles and triples “gate fractions” are calculated from the singles, doubles, and triples rates measured with the ^{252}Cf reference source. For this procedure, we do not need to know the strength of the californium source, but we need a source with no multiplication ($M=1$) and no (α, n) reactions ($\alpha=0$). Then from Eqs. 5-44 through 5-46 we can obtain the following equations for the doubles gate fraction f_d and the triples gate fraction f_t :

$$f_d = \frac{2v_{s1}D}{\epsilon v_{s2}S} \quad (6-5)$$

and

$$f_t = \frac{3f_d v_{s2}T}{\epsilon v_{s3}D} \quad (6-6)$$

where S , D , and T are the singles, doubles, and triples rates, ϵ is the efficiency, and v_{s1} , v_{s2} , and v_{s3} are the 1st, 2nd, and 3rd factorial moments of the ^{252}Cf source distribution from Table 5.2:

$$v_{s1} = 3.757, \quad v_{s2} = 11.962, \quad v_{s3} = 31.812.$$

J. Detector Characterization: Deadtime Coefficients

This section reviews the procedure required to determine the singles, doubles, and multiplicity deadtimes needed to correct the measured count rates or to verify the coefficients provided with the counter. At high neutron count rates, some of the neutron pulses are lost as a result of detector and electronic deadtime. If two neutrons are captured too close together, their pulses overlap and appear as one pulse in the counting circuits. These effects can occur in the ^3He tubes, in the preamplifier/discriminator circuits, or in the OR-ing circuits that combine the pulses for input into the multiplicity shift register. The shift register itself is inherently dead-time free, with no counts or events lost due to overlap or circuit paralysis.

Because of deadtime, the measured singles and doubles rates are smaller than they would be if no pulses were lost. Experimentally, it has been determined (by counting combinations of strong ^{252}Cf and AmLi sources) that the singles and doubles rates can be corrected for deadtime according to the following equations:

$$S_0 = S_m e^{\delta S_m/4} \quad \text{and} \quad (6-7)$$

$$D_0 = D_m e^{\delta S_m} \quad , \quad (6-8)$$

where

$$\delta = A + B S_m \quad . \quad (6-9)$$

A and B are the deadtime coefficients, the subscript “m” refers to the measured quantity, and the subscript “0” refers to the quantity corrected for deadtime. The deadtime coefficients A and B depend on the actual multiplicity counter, particularly on the number of ^3He tubes per preamplifier/discriminator circuit. Examples of values for the deadtime coefficients A and B , and the multiplicity deadtime, are given in Tables 3-1 and 6-1.

One approach for determining A and B is to very carefully and reproducibly measure several californium sources of different strengths, and adjust A and B to obtain the same doubles/singles ratio for all sources. To use this procedure, the curium and ^{250}Cf impurity content of the ^{252}Cf sources must be low so that each source should have the same true doubles/singles ratio. If so, then the NCC code can be used to reanalyze the ^{252}Cf data using “Acquire Rates only” with the data source set to “Database,” and obtain A and B by iteration. Alternatively, one can plot the expression $\ln(D_m/S_m)$ as a function of A and B , and perform a least-squares fit to obtain A and B . Using either approach, one can then enter A and B under “Edit/Detector Parameters.”

The complex equations used for correcting the triples count rate needed for multiplicity analysis are built into the NCC code, as described in Krick (93). They use a deadtime correction factor f given by

$$f = e^{\Delta S_m} \quad , \quad (6-10)$$

where Δ is a constant deadtime parameter. Also, two sets of deadtime correction coefficients α_i and β_i are defined as follows (Dytlewski 91):

$$\alpha_i = 1 + \sum_{j=0}^{i-2} \binom{i-1}{j+1} \frac{(j+1)^j \phi^j}{[1-(j+1)\phi]^{j+2}} \quad (i \geq 2) \quad \text{and} \quad (6-11)$$

$$\beta_i = \alpha_i - 1 + \sum_{j=0}^{i-3} \binom{i-1}{j+2} \frac{(j+1)(j+2)^j \phi^j}{[1-(j+2)\phi]^{j+3}} \quad (i \geq 3) \quad . \quad (6-12)$$

In these equations, $\alpha_1 = 1$, $\beta_2 = \alpha_2 - 1$, and $\phi = \Delta/G$, where G is the gate length. From these two sets of deadtime correction coefficients, two new summations called R_1 and R_2 are calculated using the measured foreground and background multiplicity distributions $f(i)$ and $b(i)$, each normalized to 1:

$$R_1 = \sum_{i=1}^{\max} \alpha_i [f(i) - b(i)] \quad \text{and} \quad (6-13)$$

$$R_2 = \sum_{i=2}^{\max} \beta_i [f(i) - b(i)] - R_1 \sum_{i=1}^{\max} \alpha_i b(i) \quad . \quad (6-14)$$

Then

$$T_0 = fS_m R_2 (1 + cS_m) \quad . \quad (6-15)$$

This deadtime correction procedure is exact for uncorrelated events, but is only approximate for the actual mix of correlated and uncorrelated events present in the multiplicity counter. An exact solution for mixed events in closed form is not yet available, but is under development in Europe.

The multiplicity deadtime parameter Δ can also be determined by measuring a weak and a strong ^{252}Cf source. The ratio of the triples rate to the doubles rate should be independent of the ^{252}Cf source strength after deadtime corrections are made, so the deadtime can be determined by adjusting Δ to give the same triples/doubles ratio. Then the multiplicity deadtime Δ is also entered under "Edit/Detector Parameters." The deadtime parameter c is usually set to zero. It can provide an extra correction factor for the triples rate when the normal multiplicity deadtime correction procedure does not provide adequate correction—usually at extremely high count rates.

K. Detector Characterization: Detectability Limit

The detectability limit, or minimum detectable mass, of a neutron counter is a useful way of describing its sensitivity at very low sample masses. This concept is usually not of interest for multiplicity counting, except for multiplicity counting of waste drums. However, if a multiplicity counter is used as a conventional coincidence counter to assay small samples, it can have a very good detectability limit because of its high efficiency, provided that room background is not too high. Different values for detection sensitivity can be obtained using the neutron singles or neutron doubles, and either can yield a lower detectability limit, depending on the background count rates. The detectability limit d (in grams of ^{240}Pu) at three standard deviations above background can be calculated for the multiplicity counter once the background count rate and calibration response have been obtained. The equation is

$$d = \frac{3}{a} \sqrt{\frac{B + ad}{t}}, \quad (6-16)$$

where a = response of counter, either singles or double counts/(s•g ²⁴⁰Pu),
 B = room background rate, either singles or doubles counts/s, and
 t = count time.

This equation assumes that the background count rate has been measured for a much longer time, so that the uncertainty in the background can be neglected. Also, it is assumed that the background rate is low enough that there are no significant number of accidental coincidences due to the background. Typical detectability limits for the Shield Cell Drum Counter (Part III, Section I) are 1 mg ²⁴⁰Pu by singles counting, and 2.5 mg of ²⁴⁰Pu by doubles counting. For 100 kg of waste, this is equivalent to 10 nCi/g by singles, and 25 nCi/g by doubles counting.

L. Measurement Control Features

This section summarizes the measurement control features of the NCC Windows code that are important for monitoring the operation of the multiplicity counter (Harker 96). Each DOE facility count room usually has an instrument certification and measurement control program that may include some of these features, but will also add other more formal requirements such as long-term performance tracking. The measurement control features that can be implemented in the NCC code are as follows:

1. Background measurements—the background values stored in the code should be updated at least once per day, and more frequently if there is reason to believe that the room background is changing significantly.
2. Bias measurements—a bias run should be made at least once per day to ensure that the counter is operating correctly.
3. Precision measurements—this option can be exercised relatively infrequently, such as once per week or once per month, using “Acquire/Precision.” It provides some indication of the run-to-run stability of the electronics and checks that the statistical error propagation is being done correctly. A precision run should consist of a long series or runs, preferably 40 or more. The final results will be the number of runs, the chi-square lower and upper limits, the sample and theoretical variance, and the chi-squared value. If this value falls outside the lower and upper limits, you will get a “Fail” message.
4. Statistical and QA flags—these tests monitor the data collected by the NCC code and include test limits that the operator can set under “Edit/Test parameters.” Runs that fail the test limits will be rejected, and additional runs will be taken to reach the total number of runs requested.
 - a. A check-sum test is always applied to the multiplicity data to check for internal consistency. There are no test parameters, because exact agreement is required. Repeated check-sum errors usually indicate a failure of the electronics package.
 - b. The accidentals/singles test (Eq. 4-4), with a usual limit of 4σ .
 - c. The accidentals/singles test rate limit, which turns off the test at rates below 1000/s.
 - d. The accidentals/singles test precision limit, which turns off the test if the accidentals and singles are constant to within 0.1%.

- e. The outlier test, which rejects runs that lie outside a limit, usually set to 3σ .
- f. The measurement control chi-squared limit, with a default value of 99%.
- g. The maximum number of allowed bad measurements, usually set to 10. For long counts at low rates, a higher number may be needed.
- h. Declared—assay quality check limit, with a default value of 3σ .
- i. High voltage test limit, with a default value of 1%.

M. Multiplicity Calibration Procedure

The calibration procedure for neutron multiplicity counting does not require a series of representative physical standards to determine a curve of instrument response versus ^{240}Pu (effective) mass. Instead, the singles, doubles, and triples equations (Eqs. 5-48 through 5-54) are solved directly for multiplication, α , and effective ^{240}Pu mass. To the extent that the plutonium samples satisfy the assumptions of the “point model” (described in Part V, Section E), the measured singles, doubles, and triples rates will correctly determine these unknowns without a calibration curve.

To implement this procedure, we need to supply the NCC code with several parameters that appear in the above-mentioned equations: the detector efficiency ϵ , the multiplicity deadtime, the doubles gate fraction f_d , and the triples gate fraction f_t . These parameters are loaded under “Edit/Detector parameters.” In addition, because the assay procedure uses the first three spontaneous and induced fission multiplicity distribution moments ν_{sk} and ν_{ik} (given in Table 5-2) as determined from the available nuclear data, these should be loaded under “Calibration/Multiplicity.”

Initial determination of the detector and electronic parameters needed for multiplicity assay can be done with a ^{252}Cf source alone. However, multiplicity assays of plutonium based on the parameters determined from ^{252}Cf alone can be biased because of uncertainties in the nuclear data parameters for ^{252}Cf and plutonium, differences in detection efficiency between ^{252}Cf and plutonium fission neutrons, and differences between the actual samples to be assayed and the assumptions of the “point model.” These uncertainties limit the accuracy of a calibration based only on californium and nuclear data to about 2% (Carrillo 98). As a result, a more complex procedure for adjusting the detector and electronic parameters has been developed and is still being refined at this point in time. The following steps provide a summary of the procedure that is currently recommended:

1. A series of californium sources can be used to determine the deadtime correction coefficients for singles, doubles, and multiplicity, as described in Section J.
2. Using one of the californium sources of known yield, the dead-time-corrected singles, doubles, and triples count rates can be used to determine initial values for the absolute neutron detection efficiency ϵ , the doubles gate fraction f_d , and the triples gate fraction f_t . The procedure for determining the detection efficiency is described in Section G, and the procedure for determining the doubles and triples gate fractions is described in Section I. These three quantities constitute the “calibration coefficients” for multiplicity counting within the framework of the “point model.” However, if possible, they should be verified or adjusted as described in the following additional steps.
3. At this stage, one should correct for the difference in efficiency between californium and plutonium by Monte Carlo calculations or by measuring an actual plutonium

standard, and adjusting the value of ϵ accordingly. The magnitude of the adjustment will depend on the actual multiplicity detector being used, but will typically be in the range of 1% to 2%.

4. Whenever possible, the three calibration coefficients should be adjusted for errors due to point-model assumptions by measuring one or more actual plutonium standards similar in size, shape, density, and mass to the actual unknown samples to be assayed. The results of this measurement can be used in several different ways, including
 - a. Adjust f_i only, since it is most sensitive to point-model assumptions and most sensitive to errors in nuclear data coefficients and energy spectrum shifts. The adjustment may be on the order of 10%, with the final assay changing by a similar amount.
 - b. Adjust ϵ only to allow for scattering and moderation in distributed samples.
 - c. Adjust ϵ , f_d , and f_i in some consistent way, not yet defined, with one standard, such as the Calex standard. After adjustment, sample mass, M , and α should all be correct to the extent to which they are known. Otherwise, the assay of actual samples will introduce a bias that increases as M or α increases. As a general guideline, if there is no independent information on the M or α values of the standards that would provide a physical basis for adjustment, it may be conservative to minimize changes to the gate fractions.
5. It may be helpful to correct all multiplicity assays for shifts in the neutron energy spectrum due to neutrons from (α, n) reactions by using the ratio of counts in the inner and outer rings. This procedure is described in the following section.
6. For large metal samples, a correction for the nonuniform probability of fission in large metal plutonium items is required. This procedure is also described in the following section. The multiplication bias correction can be applied before or after the correction for energy spectrum bias described in step 5 above. In principle, both corrections are not entirely independent of each other. A future goal is to integrate both steps 5 and 6 into the NCC code so that they can be applied in a comprehensive, consistent fashion to all assays.
7. There is a final step that can be done at the end of a large measurement campaign if other defensible documentation such as calorimetry measurements or destructive analysis show that the multiplicity assays have a small overall residual bias. Then the calibration can be adjusted in one of the following ways:
 - a. Adjust f_i only.
 - b. Adjust ϵ , f_d , and f_i in some consistent way, not yet defined, to minimize the average bias.

Of necessity, this adjustment would be intended to remove an overall bias in sample mass only, not M or α .

N. Additional Correction Factors

There are two cases of practical importance where the theoretical model differs significantly from the measured samples so that corrections are required. These are called the “energy bias correction” and the “multiplication bias correction.”

Energy bias correction: If samples are highly moderating, the neutron detection efficiency may not be constant from sample to sample. Also, past experience has shown that metal items have a slightly softer energy spectrum and a higher ring ratio than oxide items (Langner 93). Most importantly, neutrons from (α ,n) reactions may have significantly different average energies than spontaneous fission neutrons, and therefore have different detection efficiencies and fission probabilities. In the multiplicity counter, the inner ring (Ring 1) has a higher detection efficiency for low-energy neutrons, and the outer ring (Ring 3, 4, or 5) has a higher detection efficiency for high-energy neutrons (Fig. 2.6 or Fig. 7.9). Thus the ratio of Ring 1/Ring 3, 4, or 5 is a rough measure of the average neutron energy in the counter and can provide a correction for this bias.

The multiplicity electronics module contains two extra scalers to facilitate the measurement of ring ratios. These scaler values are printed out with every assay, but there is no correction factor built into the NCC software code yet. A ring ratio correction to the assay results may need to be applied to the data later in spreadsheet form. This can be done in two ways:

- a. An empirical correction can be applied based on the observed relationship between ring ratio and assay bias. A recent example of this approach is given in Ensslin (98).
- b. An iterative mathematical correction can be applied which subtracts the estimated spontaneous fission contribution to the signal in the inner and outer rings, determines a ring-ratio correction from the remaining signals, and then solves the multiplicity equations with separate detection efficiencies and fission probabilities for the (α ,n) neutrons (Krick 97b).

Multiplication bias correction: Past measurements of large metal samples have demonstrated the need to correct multiplicity analysis based on the three-parameter point model for the nonuniform probability of fission in large metal plutonium items (Fig. 7.4). Monte Carlo calculations have verified this effect, and two correction methods have been studied:

- a. An empirical correction based on the observed sample multiplication has been developed. The correction seems to be relatively consistent over most of the data collected to date, as summarized in Langner (98).
- b. When the dimensions and density of a sample are known approximately, a correction factor can be calculated to account for the variation of the neutron multiplication throughout the sample (Langner 93a).

A linear or nonlinear correction factor can be derived from either approach and installed in the NCC software code under “Calibration/Multiplicity.” There are three coefficients a, b, and c that determine a correction factor (CF1) for the effective ^{240}Pu assay mass that depends on the neutron multiplication M through the equation

$$CF1 = a + b(M - 1) + c(M - 1)^2 . \quad (6-17)$$

For no correction, set a=1, b=0, and c=0. These parameters must be determined outside the NCC program and entered manually through the keyboard. Then the NCC code will calculate CF1 based on the measured value for M and apply the correction to the assay.

O. Assay/Verification Sequence

The data collection and analysis sequence used by the NCC code for assay or verification runs is illustrated in Fig. 6.1, and summarized below (Harker 96). For each run, the foreground (R+A) and background (A) neutron multiplicity distributions are measured, and the NCC code computes their factorial moments using Eqs. 5-7 through 5-8. The singles, doubles, and triples rates are calculated using Eqs. 5-14 through 5-16. Then the sample multiplication, α , and effective ^{240}Pu mass are obtained using Eqs. 5-48 through 5-54. If the sample's isotopic composition is entered into the code's database, the total plutonium mass is calculated from Eq. 1-2.

1. For each short run of 30 s or so,
 Compute deadtime correction
 Compute measured S,D,T
 Perform statistical and QA checks
 Subtract background $S_{\text{bkg}}, D_{\text{bkg}}, T_{\text{bkg}}$
 Compute normalization correction
 Solve multiplicity equations
 Calculate total mass from isotopics
2. If there are additional runs, then for each run,
 check data for internal consistency
 if OK, add distribution to cumulative distribution
3. When series of runs is done, using the cumulative distribution,
 Compute deadtime correction
 Compute measured S,D,T
 Perform statistical and QA checks
 Subtract background $S_{\text{bkg}}, D_{\text{bkg}}, T_{\text{bkg}}$
 Compute normalization correction
 Solve multiplicity equations
 Calculate total mass from isotopics
4. For verification runs, compare with entered value
5. Compute statistical errors from population of individual runs
6. Report results and print out if requested
7. Store all data in database and in an ASCII file.

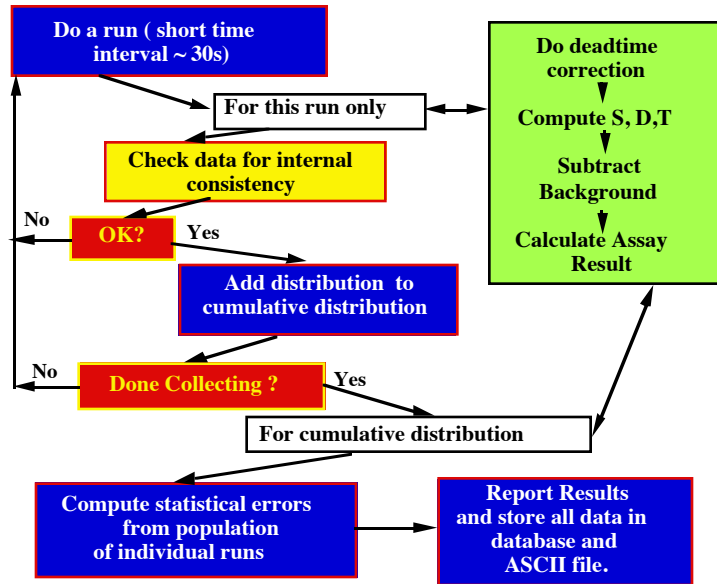

Fig. 6.1. The assay sequence used by the NCC Windows Code.

P. Measurement Error Calculation

The NCC code offers two choices for calculating the measurement errors that result from counting statistics fluctuations: theoretical standard deviation and sample standard deviation. The theoretical standard deviation is calculated using an error model based on the Figure of Merit code (see Part II, Section B). This approach estimates the true errors from sample and detector parameters, and is usually accurate to about 15%. The estimated error can be calculated from any number of runs.

The sample standard deviation is calculated from the observed scatter of repeated runs. The accuracy of this error is determined by the number of runs. The relative error of the sample standard deviation is $1/\sqrt{2n}$, where n is the number of runs. The default selection is the theoretical standard deviation. However, for highly multiplying samples, the theoretical model underestimates the true error by 50% to 100%, so sample standard deviations are recommended in this case.

VII. Applications and Expected Performance

A. Factors That Affect Multiplicity Performance

This part reviews the current applications of multiplicity counting and provides information on the performance that has been obtained, or that is expected on the basis of calculations. Most of the available performance results come from the Los Alamos Plutonium Facility, the Livermore Nuclear Materials Facility, RFETS, Hanford, or Savannah River. Most of these efforts were directed towards the measurement of impure plutonium oxide and metal in the range of a few grams to a few kilograms for which the multiplication or α value was unknown. Some mixed Pu/U oxide samples with assorted characteristics have also been measured. There is no experience yet with thorium, ^{238}Pu , or ^{233}U . Table 7.1 provides a summary of past or expected performance for multiplicity assay of many of the nuclear materials commonly found in DOE facilities.

Table 7.1. Summary of past or expected multiplicity counter performance on various nuclear material categories. A well-designed multiplicity counter with roughly 50% to 55% detection efficiency is used, unless otherwise specified in the text.						
Nuclear Material Category	SNM Mass (g)	(α ,n)/sf rate α	Counting Time (s)	Assay Precision (% RSD)	Assay Bias (%)	References
Plutonium Metal	2000 g	0 to 0.2	1000 s	7.1%	-10.6% ^a	Langner 91b
	2000 g	0 to 0.2	3000 s	5.1%	-4.7% ^a	Krick 92b
	4000 g	0 to 0.2	1800 s	2.0%	0.0%	Langner 93b
	200-4000 g	0 to 1.3	3600 s	3.3%	-1.8%	Ensslin 98
Plutonium Oxide	2000 g	1	5000 s	0.7%	0.6%	Langner 91b
	1000 g	1	3000 s	0.8%	-2.7%	Krick 92b
	1000 g	1	1800 s	2.2%	-0.1%	Langner 93b
	4000 g	1-4	1800 s	3.0%	2.4%	Stewart 95
	1000 g	1-4	600 s	1-3%	0.9%	Stewart 98
Plutonium Scrap	100 g	5	1000 s	12%	2-5%	Langner 92
	100-1200 g	1-6	3600 s	4.5%	1.5%	Ensslin 98
Plutonium Residues	120 g	13-29	3000 s	20%	2-10%	Krick 92b
	300 g	7-34	3600 s	18.9%	-4.0%	Ensslin 98
	20-100 g	8-30	3600 s	7%	7%	Langner 98
	100 g	5-9	3600 s	8.7%	3.2%	Langner P.C.
Plutonium Waste (estimated)	1 g	1	1000 s	2%	1-2%	Ensslin 95
	1 g	5	1000 s	10%	2-5%	Ensslin 95
	1 g	20	1000 s	50%	5-10%	Ensslin 95
Plutonium Oxide in Excess Weapons Materials	1000 g	1 - 10	1500 s	6.0%	0.02%	Stewart 96
	1000 g	1 - 8	1000 s	5.0%	1.0%	Stewart 97(PC)
	4000 g	1 - 6	1800 s	4.2% ^b	0.8%	Langner 96b
	4000 g	1 - 6	1800 s	5.8% ^c	-1.0%	Langner 97b
Mixed Uranium/Plutonium Oxide	300 g	1 - 2	1000 s	1-2%	1-3%	Menlove 93
Large Drum Inventory Verification	1 - 4000 g	1 - 6	6 - 12 h	10.2%	-0.5%	Rinard 97
	1 - 4000 g	7 - 50	6 - 12 h	N/A	N/A	Rinard 97

^a Assay bias quoted without multiplication correction curve for metal.
^b Assay precision based on counting statistics, gamma-ray isotopics, and scatter relative to calorimetry.
^c Assay precision based on counting statistics and scatter relative to destructive analysis.

One important question for safeguards personnel is when to use multiplicity counting versus when to use conventional coincidence counting. There are many conventional alternatives, including nonlinear calibration curves, the known- α approach, the known-M approach, ring-ratio efficiency corrections, combined active/passive measurements, and californium add-a-source, which work well on some material types. The factors to be considered for each material type to be measured are, in approximate order of importance

1. special nuclear material (SNM) mass,
2. (α,n) reactions,
3. available detector efficiency,
4. sample self-multiplication,
5. neutron energy spectrum effects,
6. spatial distribution of fissile material,
7. other matrix effects such as density, self-shielding, neutron poisons, and neutron moderators,
8. available detector die-away time,
9. available counting time/required precision,
10. count rate/dead-time effects,
11. container size and shape, and
12. room background.

To address this question, this part of the Applications Guide is broken into individual sections for each major material type. Multiplicity counter performance is considered in terms of two parameters: precision and bias. Because the principal limitation of multiplicity counters is the statistical error in the triples count, the counting precision sets a lower limit on the accuracy that can be achieved for an individual sample. And, because the counting time and precision depend primarily on mass, the (α,n) rate of the sample, and detector efficiency, these may be the most important factors. The observed assay precision is listed where available, or else estimated using a Figure of Merit approach. An example of a Figure of Merit calculation is given in Fig. 7.1 for plutonium metal ($\alpha=0$) and oxide ($\alpha=1$), scrap ($\alpha=5$), and residues ($\alpha=20$). The actual α values of such materials will vary from sample to sample, of course, but the values selected here are representative of such materials.

Assay bias for multiplicity counting is in principle very low for samples that meet the mathematical assumptions of the point model. However, in practice the other container and matrix factors listed above may yield noticeable biases. For impure samples with unknown multiplication and α , the accuracy is still usually much better than that of conventional coincidence counting, and in some cases additional corrections can be applied. Where measurement data are available, these comparisons are given in the sections below. Then, information on when to use multiplicity counting versus conventional coincidence counting is provided where available.

B. Plutonium Metal

Pure plutonium metal has no impurities that can yield neutrons from (α,n) reactions, so that $\alpha=0$. This is the most favorable case in terms of multiplicity assay precision. Figure 7.1 shows that the precision from counting statistics in a 1000-s measurement will be 0.3% to 2% over the entire mass range. However, the counting precision for conventional coincidence counting is even better. Also, the multiplicity information is not needed if $\alpha=0$, because the known- α approach can determine the mass and the multiplication from the singles and doubles rates. Thus, if samples are known to be pure plutonium metal, conventional coincidence counting will give better assays because the precision is better. If samples are thought to be pure, but not with certainty, then multiplicity counting can be used to check the conventional assay. If conventional and multiplicity results are in statistical agreement, then the conventional result can be used; if they are in disagreement, then the multiplicity result can be used.

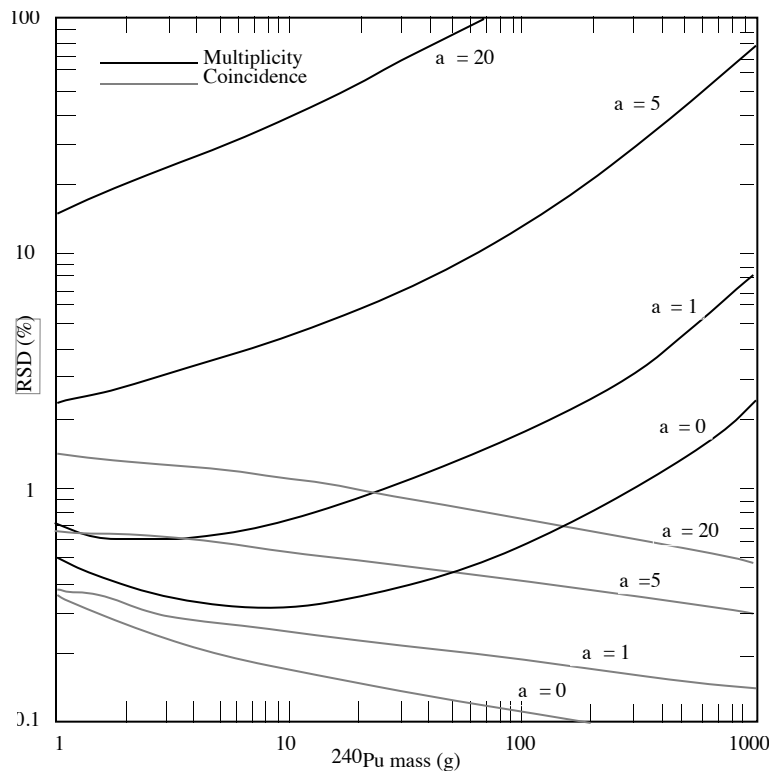

Fig. 7.1. Example of the use of the Figure of Merit code to predict precision, count time, and estimate bias in multiplicity and conventional coincidence assay. The detector efficiency is 50%, the gate width is $64 \mu s$, the die-away time is $50 \mu s$, the predelay is $3 \mu s$, the background rate is 100 counts/s, and the counting time is 1000 s.

In reality, most metal samples contain some impurities, and their surface is usually oxidized. A common sample type is plutonium metal buttons derived from molten salt extraction (MSE), many of which are fractured. These have an oxidized layer and other impurities such as chlorine, calcium, and magnesium from the MSE process that yield (α,n) neutrons. The actual α varies from near 0 to about 0.3 or more, which is large enough to ruin the accuracy of conventional coincidence counting.

Figure 7.2 compares conventional coincidence and multiplicity assays of eight plutonium metal samples measured in the Five-Ring Multiplicity Counter for 1000 s each (Langner 91b). The conventional assay/reference results average $2.665\% \pm 81\%$, the multiplicity results average $0.894\% \pm 7.1\%$. Similar measurements of five plutonium metal samples in the In-Plant Pyrochemical Multiplicity Counter at the Los Alamos Plutonium Facility showed an average assay bias of $-4.7\% \pm 5.1\%$ (Krick 92b). In both cases, the multiplicity assay of these highly multiplying samples exhibited a negative bias, and the precision was worse than expected from counting statistics. (The results presented in this paragraph do not include the multiplication correction described below.)

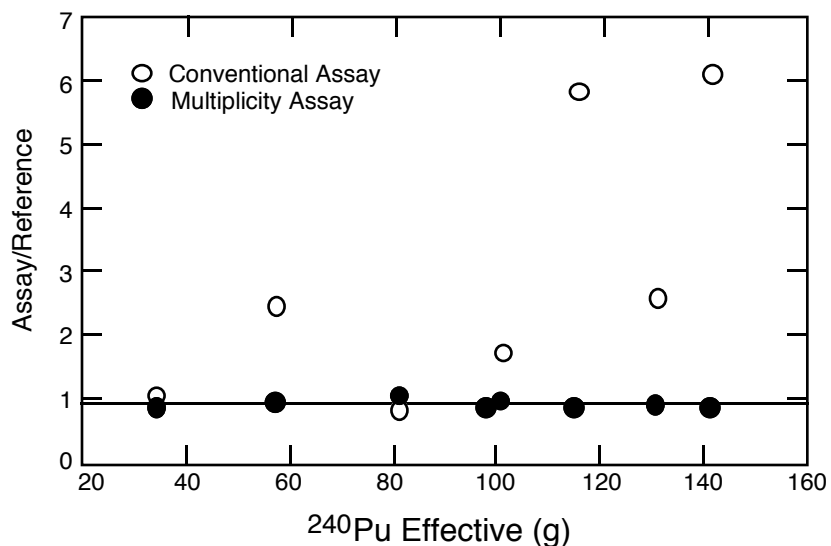

Fig. 7.2. Comparison of conventional coincidence and multiplicity assays of eight plutonium metal samples using the Five-Ring Multiplicity Counter.

Measurements of five broken MSE metal product buttons and nine unbroken plutonium metal samples in the In-Plant Pyrochemical Multiplicity Counter at the Livermore Nuclear Materials Facility are described in Langner (93b). Figure 7.3 illustrates the metal and oxide results from Livermore, and Table 7.2 compares the coincidence and multiplicity results. The negative bias in the multiplicity assays averaged -9.3% , and is correlated with sample mass. The coincidence assays assumed pure metal, $\alpha=0$, and exhibited a larger negative bias of -21.7% .

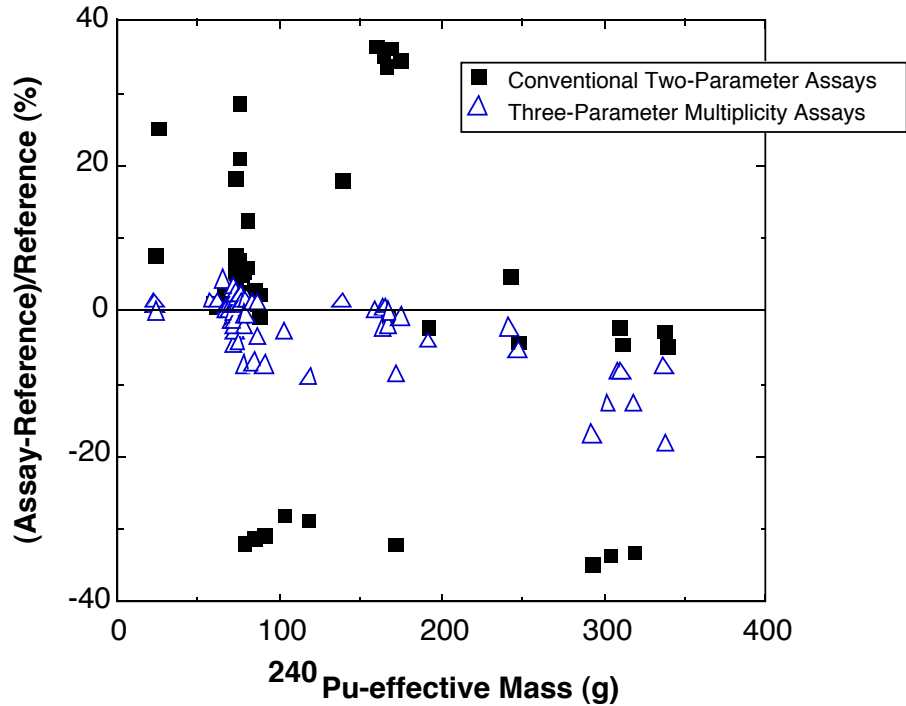

Fig. 7.3. Plutonium metal and oxide results using the In-Plant Pyrochemical Multiplicity Counter at Livermore.

Table 7.2. Summary of plutonium metal and oxide results by coincidence and multiplicity techniques using the In-Plant Pyrochemical Multiplicity Counter at Livermore.

Sample Type	Number of Samples	(Assay - Reference)/Reference (%)			
		Average Results for Two-Parameter, Conventional Assay	1 σ	Average Results for Three-Parameter, Multiplicity Assay	1 σ
Low Burn-Up Metal	10	-18.0	15.2	-9.7	5.4
High Burn-Up Metal	4	-30.9	1.6	-8.1	0.9
Metal Set 1 (Broken)	5	-3.3	1.3	-9.0	5.6
Metal Set 2 (Unbroken)	9	-28.7	9.1	-9.4	4.2
All Metal Samples	14	-21.7	14.1	-9.3	4.6
Low Burn-Up Oxide	11	23.1	15.8	-1.2	2.5
High Burn-Up Oxide	34	5.6	6.4	0.3	2.0
All Oxide Samples	45	10.0	12.2	-0.1	2.2
All Samples	59	2.3	18.5	-2.2	4.9

Plutonium metal buttons are dense, compact samples for which the theoretical point model does not correctly describe the internal multiplication, so that corrections are required. “Compact” means that the mean free path of the emitted neutrons is near to, or shorter than, the sample dimensions. If the samples have high neutron multiplication, then the probability of fission is not constant throughout the sample. MCNP simulation of this effect confirms the presence of a systematic low bias for metal, and that there is no appreciable effect in oxides. Figure 7.4 is a

compilation of all the metal data obtained with two distinctly different multiplicity counters, the In Plant Counter and the 30-gal. Large Neutron Multiplicity Counter (Langner 97a). The average reference/assay ratio is 1.073 ± 0.071 (1σ). The observed bias in the multiplicity assay is due primarily to variations in the geometry of the buttons. Monte Carlo calculations of the “correct” multiplication M for each sample showed that M varied from 1.2 to 2.0 over these samples. After application of a simple empirical bias correction, the average reference/assay ratio is 1.003 ± 0.035 (1σ). The left half of Table 7.3 summarizes this correction for the Livermore measurements. Now the average bias in the assay results is very small, and the results for metals are only slightly poorer than for oxides.

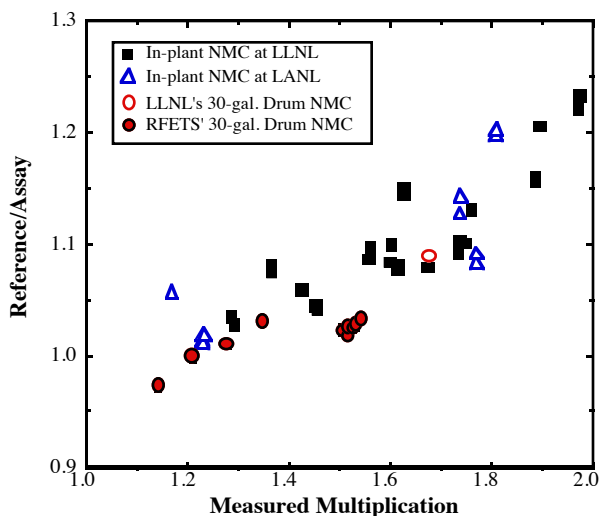

Fig. 7.4. *Compilation of plutonium metal data obtained with the In-Plant Pyrochemical Multiplicity Counter and the 30-gal. Large Neutron Multiplicity Counter.*

Table 7.3. Summary of plutonium metal and oxide results by multiplication-corrected, and both multiplication- and ring ratio-corrected multiplicity techniques using the In-Plant Pyrochemical Multiplicity Counter at Livermore

Sample Type	Number of Samples	(Assay - Reference)/Reference (%)			
		Average Results When Multiplication Corrected	1 σ	Average Results When Multiplicity and Ring Ratio Corrected	1 σ
Low Burn-Up Metal	10	-1.4	1.9	-0.3	2.2
High Burn-Up Metal	4	3.1	0.8	0.9	0.9
Metal Set 1 (Broken)	5	-0.1	1.0	1.3	0.9
Metal Set 2 (Unbroken)	9	-0.2	3.3	-0.9	2.2
All Metal Samples	14	-0.1	2.7	0.0	2.0
Low Burn-Up Oxide	11	-1.6	1.9	-1.4	2.0
High Burn-Up Oxide	34	0.7	1.9	0.5	1.4
All Oxide Samples	45	0.1	2.1	0.0	1.8
All Samples	59	0.0	2.2	0.0	1.8

Neutron multiplicity counting of plutonium metal can also be used to provide information other than assay results. For example, a serious problem that can occur during storage of metal is oxidation. As plutonium metal oxidizes, its volume increases and the production of (α,n) neutrons increases. Multiplicity measurements are sensitive to this increase, but because the geometry of the metal samples can change dramatically as they oxidize and break up, the known- α approach using conventional coincidence counting is actually more sensitive to an increase in plutonium oxide in the presence of plutonium metal.

Another application of the multiplicity counter is to provide a direct measure of the neutron multiplication of a sample. For example, a metal plutonium sample can be easily distinguished from isotopic neutron sources with a multiplicity counter. This is because the triples/doubles ratio is a direct measure of the neutron multiplication, nearly independent of sample type.

C. Plutonium Oxide

Pure plutonium oxide yields neutrons from both spontaneous fission and from (α,n) reactions in oxygen. Depending on whether the plutonium is low or high burnup, the value of α obtained from Eq. 5-3 is in the range of 0.4 to 0.8. If some impurities are present, it is conservative to estimate that $\alpha = 1$. Figure 7.1 shows that the precision from counting statistics in a 1000-s measurement will be 0.6% to 8% over the entire mass range. However, the counting precision for conventional coincidence counting is again better. Also, the multiplicity information is not needed if the oxide is so pure that α can be calculated, and the known- α approach can determine the mass and the multiplication from the singles and doubles rates. If samples are known to be pure oxide, conventional coincidence counting will give better assays because the precision is better. If samples are thought to be pure, but not with certainty, then multiplicity

counting can be used to check the conventional assay. If conventional and multiplicity results are in statistical agreement, then the conventional result can be used; if they are in disagreement, then the multiplicity result can be used.

As in the case of plutonium metal, most actual oxide samples available in DOE facilities are impure, with actual α values between 1 and 4, and multiplicity counting will be significantly more accurate than conventional coincidence counting. Figure 7.5 compares conventional coincidence and multiplicity assays of eight pure plutonium oxide samples and seven impure oxide samples measured in the Five-Ring Multiplicity Counter for 5000 s each (Langner 91b). The conventional coincidence results include the known- α correction for (α,n) reactions in the oxide. The pure oxide samples have an average assay/reference ratio of $1.004 \pm 1.4\%$ by coincidence counting, and $1.006 \pm 0.66\%$ by multiplicity counting. The impure oxide samples are $1.039 \pm 8.2\%$ by coincidence counting, and $1.005 \pm 0.68\%$ by multiplicity counting. Another example is given by Krick (92b), where five plutonium oxide samples were measured in the In-Plant Pyrochemical Multiplicity Counter at the Los Alamos Plutonium Facility, with an average assay bias of $-2.7\% \pm 0.8\%$.

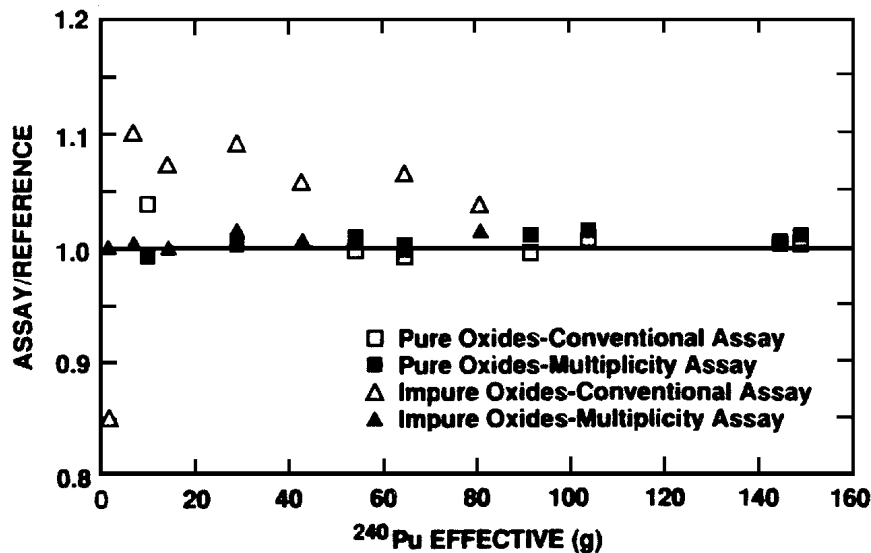

Fig. 7.5. Comparison of conventional coincidence and multiplicity assays of pure and impure plutonium oxide samples measured in the Five-Ring Multiplicity Counter.

Figure 7.3 includes data on 11 low-burnup and 34 high-burnup plutonium oxide samples measured in the In-Plant Pyrochemical Multiplicity Counter at the Livermore Nuclear Materials Facility for two 900-s runs (Langner 93b). The average precision due to counting statistics was 0.5% to 1.0%. The conventional technique used the known- α approach, so the impurities biased the results high (whereas most of the metal results were biased low). Table 7.2 compares the conventional coincidence and multiplicity results. The multiplicity assays are superior because of the effects of unknown impurities. For all 45 oxide samples, the individual assay accuracy was 2.2% (1σ). Metal and oxide samples can be distinguished by their ring ratio. There is a small correlation between ring ratio and assay bias, which can be used to develop a correction. If this is applied to the assays, there is an additional small improvement, as given in Table 7.3. With the additional ring ratio correction and the multiplication correction described in the previous section,

the counter assayed all metal and oxide samples to 1.8% (1σ). The multiplicity analysis displays no statistically significant bias, and the scatter in the results is consistent with the expected uncertainty in the reference values and the precision calculated in Fig. 7.1.

Figures 7.6 and 7.7 provide another comparison of conventional and multiplicity results for 21 heterogeneous plutonium oxide inventory samples using the Three-Ring Multiplicity Counter at Hanford (Stewart 95). Some of these samples were pure oxide, but most were impure. The passive calibration (Fig. 7.6) and known- α (not illustrated) approaches did not work well because of the enhanced coincidence rates that result from induced fissions caused by an unknown number of (α, n) neutrons. The quality of the known-M approach (not illustrated) depended on the density variations in the sample set. Multiplicity (Fig. 7.7) gave the lowest overall bias, but required long count times for samples with high α values. Most measurements were 1800 s. Several high- α samples were measured overnight. The loss of counting precision with increasing α was illustrated in Fig. 7.1 and is shown specifically for this type of heterogeneous oxide in Fig. 7.8 (Stewart 96). The value of α ranges from 1.3 to 10.4, and as a result, the greatest source of error is the counting statistics on the triples rate.

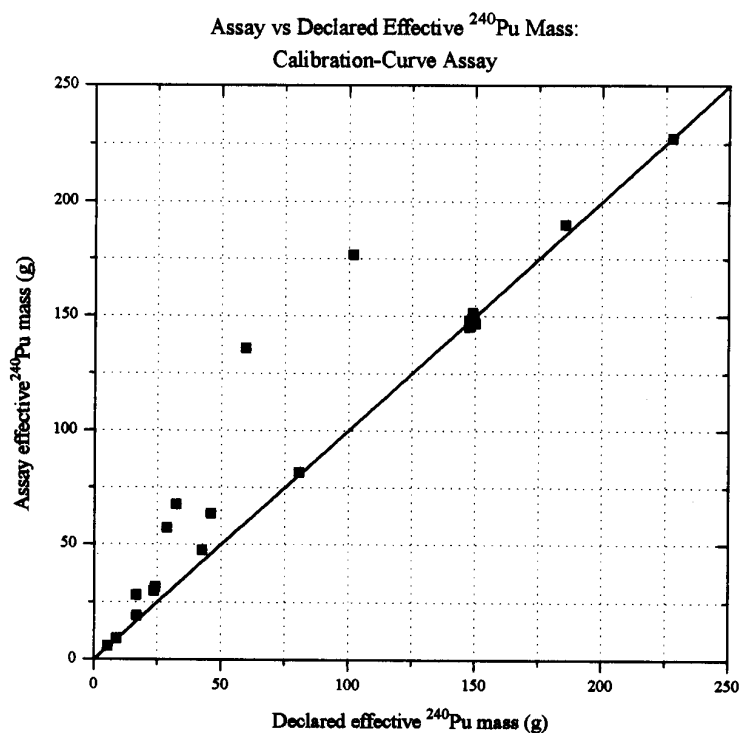

Fig. 7.6. Results for assay of 21 heterogeneous plutonium oxide inventory samples with a passive coincidence calibration curve, using the Three-Ring Multiplicity Counter at Hanford.

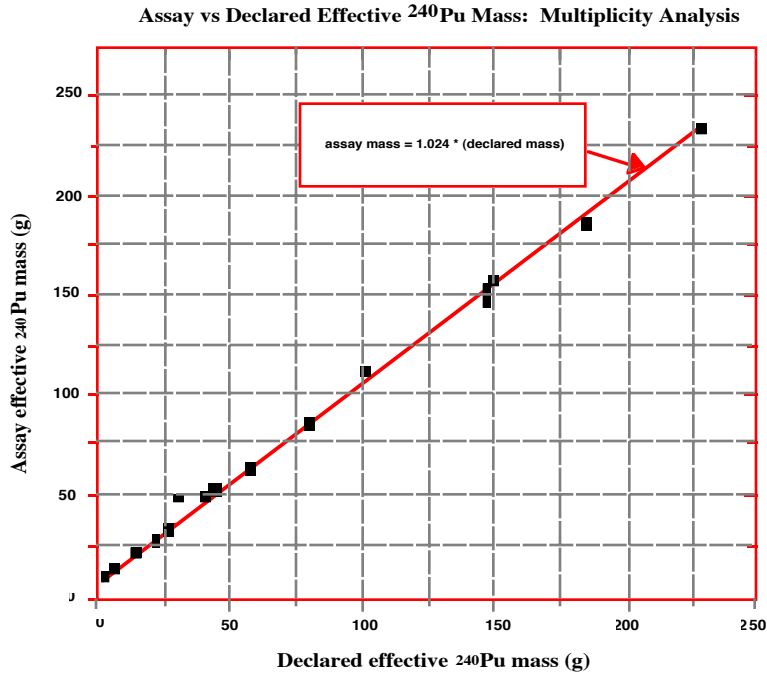

Fig. 7.7. Results for assay of 21 heterogeneous plutonium oxide inventory samples with multiplicity analysis, using the Three-Ring Multiplicity Counter at Hanford.

D. Plutonium Scrap

Plutonium scrap is plutonium-bearing materials that are left over from processing activities, and that can be recycled in the future. Scrap can include relatively pure metal or oxide, or materials with large quantities of matrix elements like fluorine and beryllium. For the purpose of this Applications Guide, scrap may be defined as plutonium samples with α values in the range of 1 to 10.

If the scrap samples are known to be impure, then the best passive neutron measurement technique depends on the nature of the sample. For example, a highly multiplying impure plutonium metal sample is best assayed with multiplicity counting, but a sample with very low multiplication and very high (α, n) rate (like waste) is best assayed with conventional coincidence counting, such as the known-M approach. The curve for $\alpha=5$ in Fig. 7.1 shows that the expected multiplicity precision for scrap in the range of 1 to 100 g ²⁴⁰Pu is in the range of 2% to 12% in 1000-s counting time, whereas the precision for conventional coincidence counting is about 0.5%. The loss of counting precision with increasing α was also illustrated in Fig. 7.8 (Stewart 96). Thus the selection of multiplicity or coincidence counting will depend very much on the form of the material, and whether the lower bias in the multiplicity assay, which can correct for induced fissions, will outweigh the loss of counting precision.

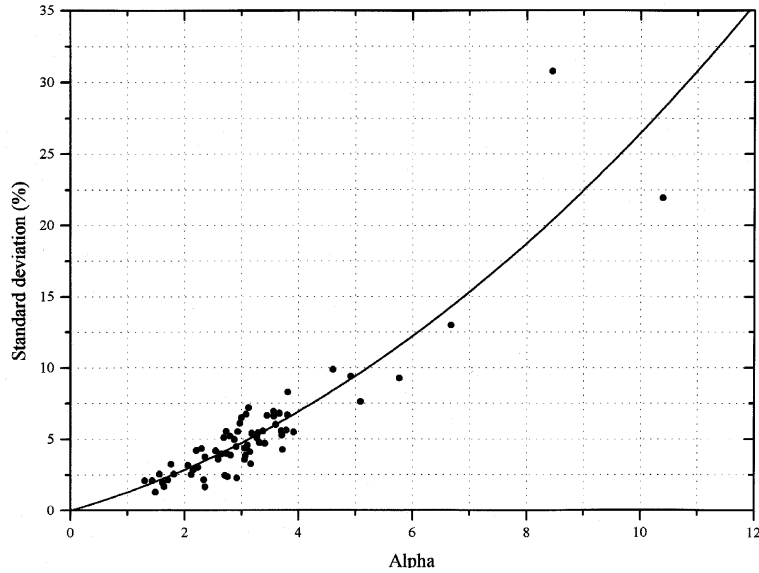

Fig. 7.8. The relative standard deviation of the multiplicity assay mass from counting statistics vs α for 1200-s measurements of 67 samples of heterogeneous oxide.

If the plutonium scrap samples contain moderating materials, or if they emit enough (α, n) neutrons with energies much different from fission neutron energies, as listed in Table 5.5, then the neutron detection efficiency will vary from sample to sample. In this case, a multiplicity counter will have another advantage because it is designed so that the detector efficiency is insensitive to neutron energy. In addition, the ratio of counting rates in the inner and outer rings of ^3He tubes is sensitive to neutron energy and can be used to correct for variations in the average neutron energy spectrum. The multiplicity electronics module contains two extra scalers to facilitate the measurement of ring ratios.

Measurement experience confirms that samples containing large quantities of impurities display dramatic changes in their ring responses (Langner 92). Figure 7.9 illustrates the measured ratio of Ring 1 to Ring 4 as a function of approximate mean neutron energy for various samples in the In-Plant Pyrochemical Multiplicity Counter. The ring ratio information can be a valuable tool in identifying samples that contain gross impurities and in distinguishing metal from oxide. However, because this multiplicity counter was designed to be insensitive to variations in the energy of the emitted neutrons, there are no strong correlations between the ring ratios and the assay results. A ring ratio correction can be determined by an empirical fit to the observed relationship between ring ratio and assay bias, or by the use of an iterative mathematical correction (Krick 97b).

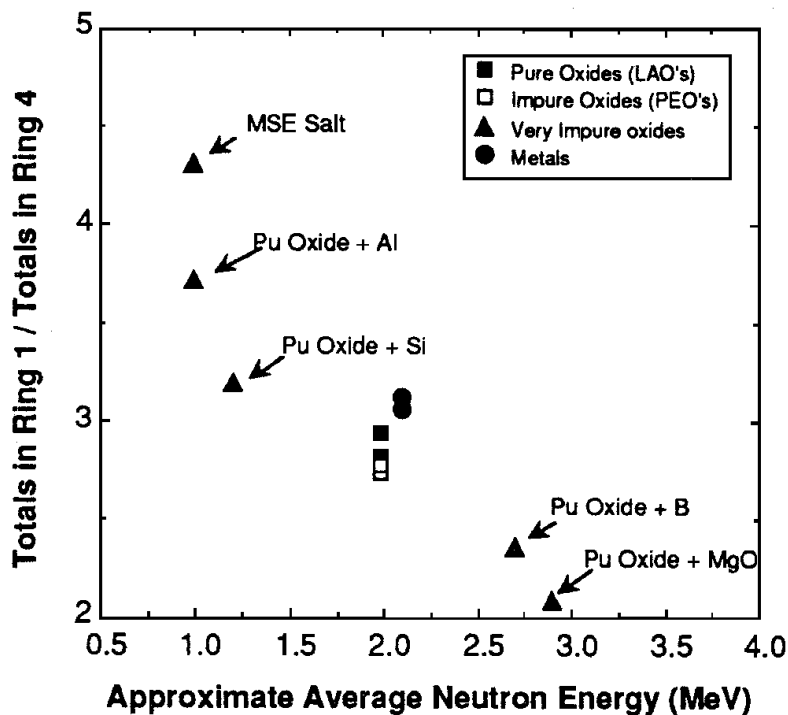

Fig. 7.9. The measured ratio of Ring 1 to Ring 4 as a function of mean neutron energy for various samples in the In-Plant Pyrochemical Multiplicity.

E. Plutonium Residues

Residues are plutonium-bearing materials that were retained during production operations because the recovery of the plutonium was deemed less expensive than the cost of producing new material in a reactor. They can include ash, combustibles, inorganics, salts from pyrochemical processes, and wet items. Residues often represent a significant portion of the accountable item and mass inventory, and sometimes require stabilization and/or repackaging.

The residues in some DOE facilities represent categories of material that are difficult to measure. They are often packaged in large cans or drums, have significant quantities of SNM, and are very heterogeneous. They often contain interfering radionuclides such as ^{241}Am which can degrade gamma-ray, calorimetry, or neutron assay. Calorimetry may be the preferred option for items that are not too large and that do not have a very high ^{241}Am content. Tomographic gamma scanning may be a quicker preferred option for cans or drums that do not contain lumps too dense for the emitted gamma-rays to escape. Among the passive neutron techniques, multiplicity counting is the only feasible option because residue assay will require penetrating radiation, a flat energy response, very high efficiency to collect triple coincidences with tolerable precision, and a ring-ratio correction to deal with changes in the neutron energy spectrum.

Because many residues contain large quantities of matrix elements like fluorine and beryllium, they may exhibit α values of 10 to 30 or more. The multiplicity technique is not well suited for samples that produce many more (α, n) neutrons than spontaneous fission neutrons because the errors from counting statistics are large. Such materials cannot be assayed successfully by multiplicity without extremely long count times to get good precision on the triples. This is suggested by the curve for $\alpha = 20$ in Fig. 7.1. However, for plutonium samples

with unknown (α, n) rates, multiplicity analysis will be far less biased than conventional coincidence counting, particularly if a ring-ratio correction is used to compensate for changes in the neutron energy spectrum.

An example is the assay of 10 high- α plutonium samples in the In-Plant Pyrochemical Multiplicity Counter at the Los Alamos Plutonium Facility (Krick 92b). The samples were electrorefining salts or molten-salt extraction salts, most with high ^{241}Am content. The values for α were between 13 and 29. The average assay bias for these items was low, $0.9\% \pm 4.8\%$, but the typical RSD that would be expected for a 1000-s measurement is 20%. Other examples included in Table 7-1 are high- α ash, salts, and crucibles measured at Los Alamos (Ensslin 98); sand, slag, and crucible measured at Savannah River (Langner 98); and direct-oxide-reduction (DOR) salts measured at RFETS (Langner, private communication).

F . Plutonium Waste

There is considerable interest in applying passive neutron multiplicity counting to 55-gal. waste drums, even though waste drums may contain only a few grams of plutonium. The additional information available from multiplicity counting can flag the presence of shielding materials, detect highly multiplying items that should not be present, or improve assay accuracy by correcting for matrix effects such as (α, n)-induced fission or detector efficiency variations. No published performance data are available yet, but the expected assay precision for multiplicity analysis of waste drums has been estimated using a Figure of Merit code (Ensslin 95).

Figure 7.10 plots the estimated precision for neutron coincidence and multiplicity assay of waste as a function of α , if the multiplicity information is used to solve for mass, M , and α (Ensslin 95). The assumed detector efficiency is 35%. The figure shows that the multiplicity assay of relatively clean plutonium waste, with α values between 0.5 and 5, will have an RSD in the range of 2% to 10%. This is not the same high precision and accuracy that multiplicity counters can achieve for the assay of small cans of plutonium, but does show that multiplicity of waste is feasible with high-efficiency drum counters. Waste with high fluoride content may have α values of 20 to 150, and the RSD will rise to 20% to 100% or more. Even with this poor precision, multiplicity assay may be much more accurate than conventional coincidence counting because the bias caused by (α, n) induced fissions is corrected.

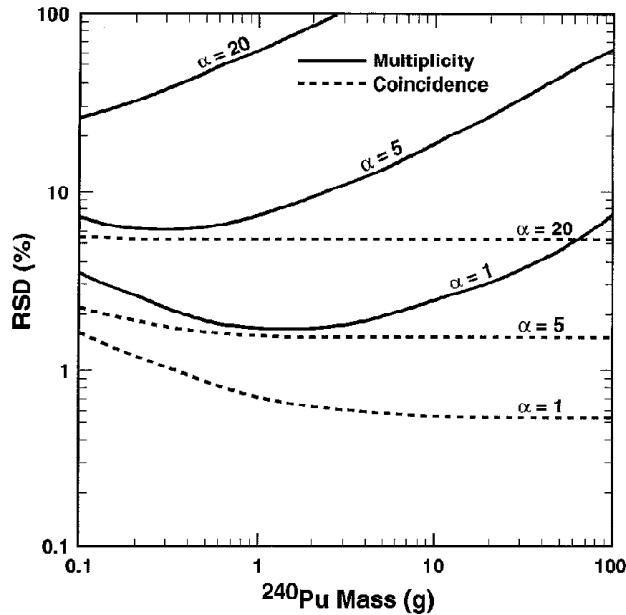

Fig. 7.10. Estimated precision for neutron coincidence and multiplicity assay of waste as a function of α , if the multiplicity information is used to solve for mass, M , and α . Efficiency = 35%, gate width = 64 μ s, die-away time = 100 μ s, counting time = 1000 s, and background = 10 counts/s.

When we use multiplicity analysis to solve for detector efficiency rather than sample multiplication, the multiplicity RSD increases by a factor of 3 to 4 over the entire mass range (Ensslin 95), and will be 5% to 15% at best. Because the use of multiplicity analysis to solve for detector efficiency significantly increases the RSD, alternative techniques for determining efficiency, such as segmented add-a-source (Menlove 96) or ring-ratio analysis (Langner 92) should be employed.

The precision for waste assay estimated from the Figure of Merit code is included in Table 7.1, and rough estimates of the expected bias due to remaining matrix effects are also included. What is the optimum tradeoff between multiplicity analysis of waste, which has worse precision but less bias, and conventional coincidence assay of waste, which has better precision but worse bias? Pickrell (97a) has developed a tunable multiplicity approach that would select coincidence counting at low mass, where coincidence has better precision, and would select multiplicity at higher mass, where coincidence is biased by (α, n) -induced fissions. The example in Fig. 7.11 compares the total error in tunable multiplicity with the total errors in coincidence and multiplicity counting (Pickrell 97a).

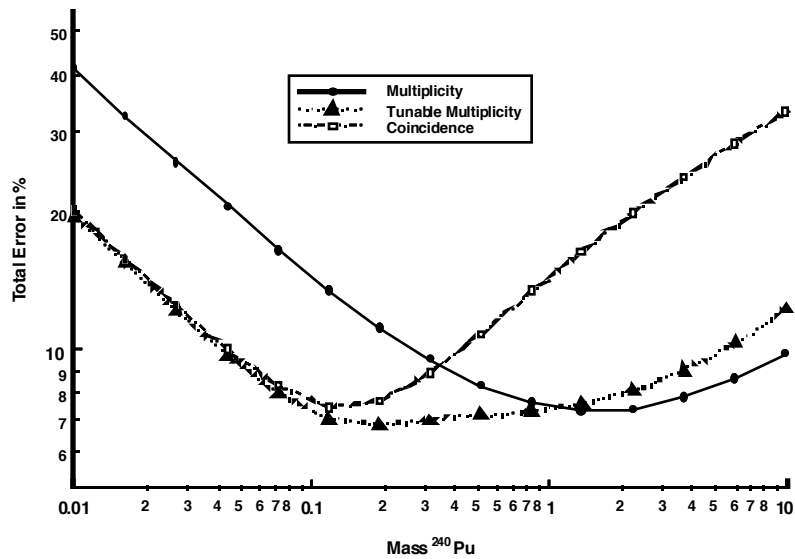

Fig. 7.11. Comparison of the total error in tunable multiplicity with the total errors in coincidence and multiplicity counting, Detection efficiency = 20%, $\alpha = 1$, and counting time = 100 s.

For multiplicity assay of waste, the drum counter should be operated with a room background in the range of 10 to 100 counts/s. Higher values will seriously degrade both coincidence and multiplicity assay RSD over the low mass range of 1 to 50 g of plutonium. At very low fission rates, corrections for cosmic-ray events can be made with a gate multiplicity analysis method (Krick 97a) or with a Pulse Arrival-Time Recording Module (Arnore 92, Brunson 97). Typical detectability limits that can be obtained with low backgrounds are 1 mg ²⁴⁰Pu by singles counting, and 2.5 mg of ²⁴⁰Pu by doubles counting. For 100 kg of waste, this is equivalent to 10 n Ci/g by singles, and 25 n Ci/g by doubles counting. The triples count rate information is not useful for counting near the detectability limit.

G. Verification of Plutonium Oxide in Excess Weapons Materials

During the past few years, the IAEA has begun to inspect containers of plutonium oxide that DOE has declared as excess weapons materials at Hanford and RFETS (Stewart 95). At Hanford, the initial offering consisted of over 500 items and included plutonium oxide (500 to 1600 g) and residue items (300 to 1700 g), each packaged in three nested cans. The second offering included over 600 items of scrap material (800 to 1100 g per item) (Stewart 96). The Physical Inventory Verification (PIV) process involves selecting items from this large offering of heterogeneous materials and carrying out a combination of gamma-ray isotopic, neutron multiplicity, calorimetry, and destructive analysis measurements. For verification of heterogeneous materials, calorimetry/isotopics determines the most accurate plutonium mass in most cases. Multiplicity/isotopics quickly verifies the authenticity of the item and determines the plutonium mass in most cases at the partial defects level.

At Hanford, the initial PIV campaigns used the Three-Ring Multiplicity Counter, which has a 45% detection efficiency, and an efficiency profile which is not as constant as for most well-designed multiplicity counters (Stewart 96). Figure 7.12 shows the verification results for 69 items counted for 20- to 30-min count times. The data points include 1 σ error bars from counting statistics. The average percent difference between declared and assay mass is $0.02 \pm 0.83\%$.

Twenty-eight of the measurements lie within the 3% limit set for bias defects, and 67 lie within the 18% limit set for partial defects. So 67 passed the IAEA acceptance criteria, and two were selected for destructive analysis.

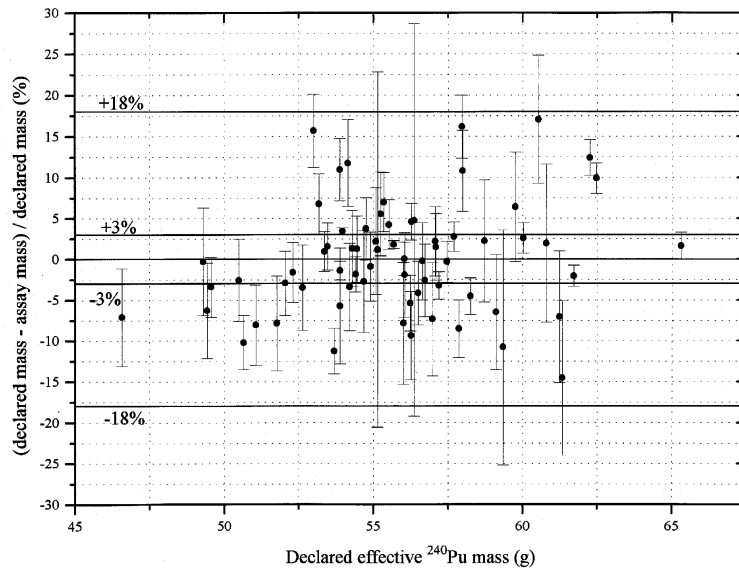

Fig. 7.12. Physical Inventory Verification results for 69 items using the Three-Ring Multiplicity Counter at Hanford.

For these 69 samples, α ranged from 1.3 to 10.4. There is little if any correlation between the declared/assay mass difference and the sample's α and multiplication. The greatest source of error is the counting statistics on the triples rate (see Fig. 7.8 above for a graph of the RSD from counting statistics versus α for these samples). For example, one of the items that failed the acceptance criteria and was selected for destructive analysis was measured just once for 1200 s, with a difference of 22%. The statistical uncertainty was about 13% because α was about 6. A longer count time would probably have given agreement, because destructive analysis gave good agreement with declared plutonium mass.

At RFETS, several PIV campaigns have been conducted using the Large Neutron Multiplicity Counter, which has an efficiency of 42% (Langner 95). The offered materials are stored in 10-gal. drums, with each drum containing two plutonium oxide cans, one above the other. Each can contains up to 2-kg each, so the total drum loading is 1 to 4 kg. The plutonium is 6.0% ^{240}Pu , with a 2% to 6% relative uncertainty in book value. The α values ranged from 1 to 6. All samples were measured for 30-min counting times, although samples with the larger α values should be counted longer. There was no significant bias in the assay results due to the presence of two plutonium oxide cans stacked one above the other. Figure 7.13 illustrates similar results obtained at Los Alamos with both single and stacked samples. The five highest mass samples are stacked oxides, and there is no observable bias relative to the single cans.

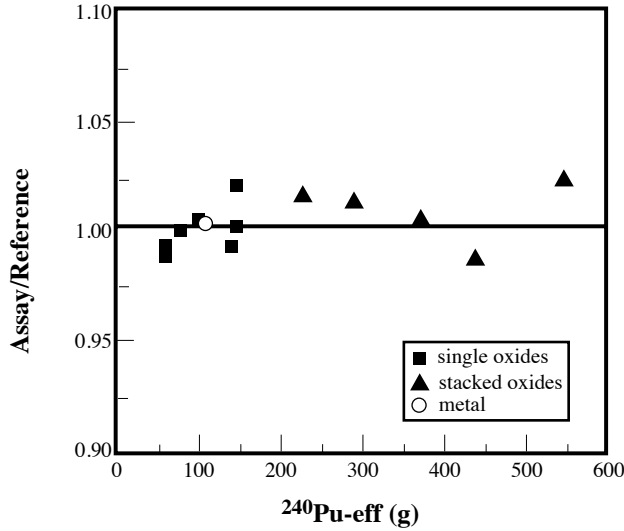

Fig. 7.13. Multiplicity assay results for single and stacked plutonium samples using the Large Neutron Multiplicity Counter.

Figure 7.14 compares known- α conventional coincidence assay and multiplicity assay for some of the RFETS PIV measurements (Langner 96b). Multiplicity improved the average agreement between declared and assay by nearly a factor of two over the best conventional approach (in this case, actually the known-M approach). The RSD due to counting statistics alone averaged 2.6%, and eight samples had α values such that their estimated counting precision was higher than 5%. Multiplicity verified 61% of the samples to within $\pm 3\%$, and 100% to within $\pm 18\%$. Overall, 1σ agreement between multiplicity and site declarations was 4.2 % for all samples.

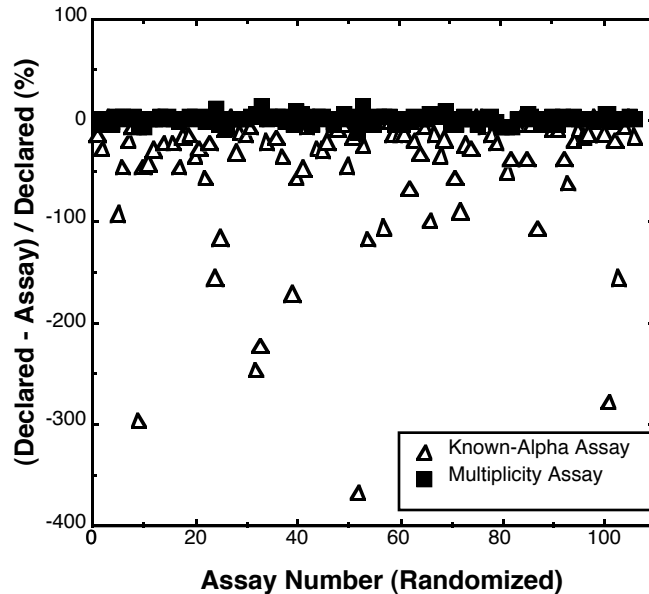

Fig. 7.14. Comparison of known- α conventional coincidence assay and multiplicity assay for some of the RFETS PIV measurements using the Large Neutron Multiplicity Counter.

Figure 7.15 summarizes the initial PIV and first annual PIV measurement results for 112 impure plutonium oxide drums (Langner 97b). One drum had such high impurity and radiation levels that it could not be assayed by the Large Neutron Multiplicity Counter (α was in excess of 40). For this type of drum, calorimetry of the individual cans or sampling and destructive analysis are the preferred techniques. The combined result for the other 111 was an average-declared minus assay of $0.75\% \pm 4.17\%$ (1σ). For 24 drums that were sampled for destructive analysis, the comparison was $-1.0\% \pm 5.79\%$ (1σ). The increase in bias and precision was observed only on drums with heterogeneous characteristics and is most likely due to sampling error and the presence of more impurities in those drums.

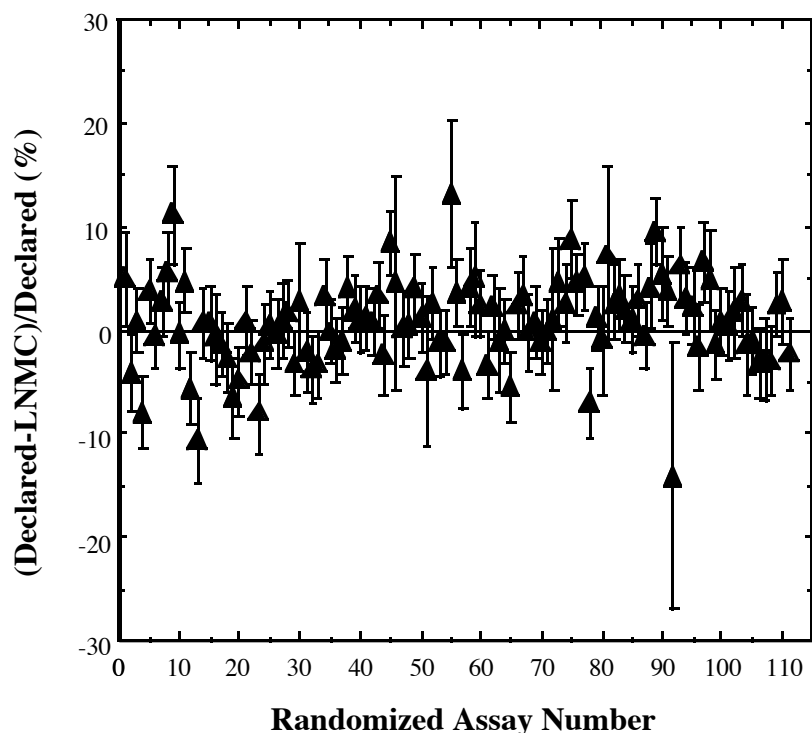

Fig. 7.15. Summary of initial PIV and later PIV measurement results for 112 impure plutonium oxide drums measured at RFETS using the Large Neutron Multiplicity Counter (Langner 97b). (From LA-UR-97-2650)

H. Mixed Uranium/Plutonium Oxide

Mixed oxides are materials that do not meet all of the assumptions used in the multiplicity mathematics, and therefore must be assayed with caution. The induced fission multiplicity distributions, fission cross sections, and capture cross sections in uranium are different from those in plutonium. However, the multiplicity analysis approach described in Part V above does not incorporate two different sets of nuclear data information. If the calibration constants appropriate for plutonium (detector efficiency, double and triple gate fractions) are used to assay plutonium oxides that have a large uranium concentration relative to their plutonium content, the assay results will tend to bias low (Langner 97a). Of course, if those constants are adjusted to fit a particular mixed oxide material type with a fixed U/Pu ratio, then the multiplicity performance will be good.

The first Plutonium Scrap Multiplicity Counter was fabricated for IAEA verification activities in a MOX facility in Japan. The counter is used to verify relatively large scrap and MOX containers with variable impurities, most of which fit within the flat portion of the counter's efficiency profile. A typical high-burnup MOX sample containing a few hundred grams of plutonium gives 1% to 2% assay precision in a 1000-s measurement (Menlove 93).

I. Mixed Uranium/Plutonium Inventory Verification in Large Drums

A novel and difficult application of multiplicity counting to bulk inventory verification at Savannah River was recently reported by Rinard, McClay, and others (Rinard 97). The inventory consisted of cans of plutonium and/or uranium stacked in varying configurations in sealed 5-, 10-, 30-, or 55-gal. drums. The SNM was in metal, oxide, scrap, scrub alloy, or other forms. For the plutonium, α values ranged from less than 1 to about 50. For the uranium, the enrichment varied from 0.22% to 93%.

Verification of this difficult-to-measure inventory required a combination of NDA instruments large enough to accommodate 55-gal. drums. A large segmented gamma scanner was used to scan the drums for the location of the cans and verify the isotopic composition by high-resolution gamma-ray spectroscopy. A 55-gal. drum californium shuffler was used for both delayed neutron counting of uranium and passive neutron counting of plutonium. This shuffler was not designed for multiplicity counting; multiplicity electronics was added with no other changes. The low detection efficiency of about 18% was not a problem for most of the drums because long count times were available. However, the strong dependence of the detection efficiency on the neutron energy introduced a bias into the assays because the energy of the neutrons from (α ,n) reactions was unknown.

The passive neutron data were analyzed four ways: (1) with a linear coincidence calibration curve, (2) with a nonlinear coincidence calibration curve, (3) with the conventional known- α multiplication correction, and (4) with multiplicity. For low plutonium masses (less than 15 g declared) the neutron multiplication was assumed to be 1, and the assay mass was determined from the linear coincidence calibration curve. For all other drums, the level of multiplication and impurities was sufficient to require multiplicity counting. Multiplicity counting was found to provide a higher level of verification than is possible with conventional coincidence counting because it required less initial information about the inventory. A potential liability of multiplicity counting in this case was that the sample cans were stacked with two or more to a drum. The mathematical assumption used in coincidence and multiplicity counting, that the sample is a point source, has a worse effect on multiplicity counting. However, in this measurement campaign, no additional biases were observed in the multiplicity assays that could be attributed to this effect.

For this Savannah River inventory, 73 of the 90 drums containing plutonium were verified to within 25% (Rinard 97). The total average bias is only -0.5%, and the average assay minus declared standard deviation is 10.2%. The 17 remaining drums could not be verified for a variety of reasons. Eight of the drums had α values between 7 and 50, which are too large for multiplicity assays in this shuffler because of the large statistical errors and the strong energy dependence of the detection efficiency. These drums cannot be assayed by passive neutron counting in this instrument. A few drums showed statistically significant coincidence rates equivalent to some grams of plutonium, although none was declared. Some of these apparent masses may be real, and represent mislabeling for items. Others may be due to induced fissions in uranium or

spontaneous fissions in other elements, and some may be due to cosmic ray events in high-Z materials in the drums.

J. Comments on Inventory Verification by Multiplicity Counting

Sections G and I provided examples of measurement campaigns where multiplicity counting was quite successful for inventory verification. Some general comments are given here based on the work referenced in those two sections and on a recent study of 50 measurements, referenced to calorimetry/gamma-ray isotopics, at the Los Alamos Plutonium Facility (Ensslin 98).

It is helpful to segregate items being considered for multiplicity counting into categories such as calibration and measurement control standards, plutonium metal, low- α plutonium (impure oxides and scrap), and high- α plutonium (residues with $\alpha > 6$). These categories can be defined by the observed assay results for sample multiplication, mass, α , or measurement precision.

For high- α plutonium, multiplicity counting can be useful but is not the preferred technique because of the long counting times required. For the other categories, counting times of 1800 s (half an hour) are usually sufficient to eliminate counting statistics as a significant contribution to the overall assay precision. It may be helpful to do all assays at 1800 s, then decide on the basis of the observed α whether additional counting time is warranted. For metal items, the data analysis procedure should include at least a multiplication bias correction, and for impure plutonium items the procedure should include at least an energy bias correction.

The overall assay precision of multiplicity counting for total plutonium mass has a lower limit of about 3% RSD once the error on the ^{240}Pu -effective as determined by gamma-ray isotopics is folded in. This limits the potential performance of multiplicity counting relative to calorimetry if the isotopic composition is determined from gamma-ray analysis. At some facilities, the use of stream-average isotopics may provide better results and can eliminate the time required to do gamma-ray isotopics.

Multiplicity counting can be a useful technique for inventory verification. It should be possible to verify about 75% or more of a diverse inventory of plutonium metals, oxides, salts, and residues to about 5% accuracy in one-half hour counting times. For a variety of reasons related or unrelated to the multiplicity technique itself, one can expect some fraction of the measurements to be well outside the reasonable expected limit of error. These will still require calorimetry and/or gamma-ray isotopics to resolve. However, multiplicity counting can substantially reduce the number of items that require calorimetry and gamma-ray isotopic analysis and allow an increase in facility measurement throughput.

VIII. Multiplicity Counter Selection and Procurement

A. Summary of When to Apply Multiplicity Counting

One important question for safeguards personnel is when to use multiplicity counting versus when to use conventional neutron coincidence counting or calorimetry. This is a complex question because multiplicity counting lies between conventional coincidence counting and calorimetry in terms of accuracy and count time requirements. Also, there are many conventional coincidence alternatives, including nonlinear calibration curves, the known- α approach, and the known-M approach, which work well on some material types.

Part VII of this guide provided some detailed information on the performance that could be expected from multiplicity counting for many common material types. Estimates for the expected precision and bias of multiplicity counting were given in Table 7-1. More experience is required to determine the accuracy of multiplicity counting for some sample types, but some general conclusions from Part VII are as follows:

- (1) If samples are known to be pure plutonium oxide or metal, then conventional coincidence counting will give better assays than multiplicity counting because the (α, n) yield can be calculated and does not need to be measured.
- (2) If samples are thought to be pure, but not with certainty, then multiplicity counting can be used to check the conventional assay. If conventional and multiplicity results are in statistical agreement, then the conventional result can be used; if they are in disagreement, then the multiplicity result can be used.
- (3) For impure materials with high (α, n) reaction rates, the overall performance of multiplicity counting is significantly better than conventional coincidence counting even though the precision is significantly degraded as the (α, n) reaction rate goes up. If the (α, n) reaction rate is very high, the counting time required for multiplicity will approach or exceed that required for calorimetry. Then calorimetry should be used, if available.
- (4) Multiplicity counting provides a higher level of verification than is possible with conventional coincidence counting because less information about the sample is needed. In general, when multiplicity hardware and software is available, the multiplicity information should be collected, either to improve assay accuracy or to provide additional diagnostic information.
- (5) Calorimetry is inherently a more matrix-insensitive NDA technique than multiplicity counting. Where calorimeters are available with large enough wells to accommodate the samples, and the longer count times are acceptable, they will usually provide more accurate results.

With these general conclusions in mind, the following sections describe more specifically the criteria to be considered in selecting a multiplicity counter. For some material types and facility requirements, conventional coincidence counting or calorimetry may be the appropriate choice instead.

B. Sample Selection Criteria

The physical size of the sample container determines the assay chamber size. Also, the taller the sample container, the longer the required ^3He tube length to help maintain a flat spatial efficiency profile throughout the assay chamber. A flat spatial profile is important because the material distribution or container fill height is usually variable from sample to sample. For containers with distributed plutonium sources, a flat spatial efficiency profile is even more important to reduce deviations from the point model that affect the multiplicity analysis.

For scrap and waste materials with low plutonium content, the detectability limit may be an important criterion. It is a function of the detector efficiency, background count rate, and counting time, as defined in Part VI, Section K, and an external shield may be required to get a low limit. To achieve a specific assay RSD in reasonable counting times of 15 to 30 min, high detection efficiency may be required, which implies a large number of ^3He tubes. For high plutonium mass samples, other counter properties become important. The counter die-away time should be low to minimize the accidental coincidence background, and the electronics should have low counting deadtime to minimize counting losses. The number of ^3He tubes per Amptek preamplifier should be small, and a shift-register-based electronics package should be used. This combination can accept count rates up to the order of 1 MHz without serious deadtime losses. To reduce the self-multiplication in large samples, a cadmium-lined sample well is used to reduce multiplication of return neutrons from the polyethylene and to improve the criticality safety of the counter. For very large samples, it may be important to use a sample well small enough to prevent double batching of samples in the well.

Other sample matrix effects present in small or large samples include (α,n) reactions and neutron moderators or poisons. For high (α,n) reaction rates, low counter die-away time helps to reduce the accidental coincidence background. Flat energy spectrum efficiency is also important so that the counter has roughly the same efficiency for detecting neutrons from spontaneous fission and from (α,n) reactions. If the sample matrix contains water or other hydrogenous materials that moderate neutrons and reduce their energy spectrum, the multiplicity counter should definitely have a flat energy spectrum efficiency to mitigate the change in neutron detection efficiency. The effect of neutron poisons in the sample is not easily observed, but a flat energy spectrum efficiency will mitigate the effect of a shift in the emitted neutron energy spectrum, and a cadmium-lined sample well will dampen the effect of thermal neutron capture in the poisons.

Samples with high americium content are not only strong sources of (α,n) neutrons, but also strong sources of 60-keV gamma rays. To avoid exceeding the ^3He tube dose limit of about 1 R/h, it is sometimes helpful to use a thick cadmium liner on the sample well to increase the attenuation of these gamma rays. For irradiated materials that emit higher energy gamma rays, a lead-lined sample well is used.

C. Facility Selection Criteria

DOE facilities currently use neutron counters for both in-line and at-line applications. Unsealed process materials inside glove boxes can be assayed by extending a well down from the glove box and installing an in-line counter around the well, such as the ARIES Neutron Counter (Part III, Section F). An in-line counter will have to be low enough to be installed under the glove-box line. For canned, sealed plutonium samples, a freestanding at-line counter can be used to

assay samples near the glove-box line or in a separate NDA counting room. An at-line counter will need to be small enough to fit into the available floorspace and headroom.

For either in-line or at-line applications, if the sample and/or the top end-plug are too heavy for an operator to remove and insert easily, a motor-driven sample lifting mechanism may be attached to the well counter. If the top end-plug is very heavy, or if the height of sample entry above the floor needs to be minimized, a front-loading design may be used, such as the Large Neutron Multiplicity Counter (Part III, Section H). If there are significant background neutron sources from process lines or nearby material storage areas, an external shield of polyethylene should be added.

For verification of inventory samples by DOE or IAEA inspectors, it is sometimes necessary to move the multiplicity counter from one building or site to another. For such applications, it is important to minimize the overall size and weight of the counter. Design features that make a neutron counter more portable include no external shield, less ^3He tube rings, and shorter ^3He tube length.

If low assay bias is important to make the multiplicity data useful to the facility accountability system, the counter should have a flat spatial efficiency profile and nearly flat energy spectrum efficiency. Assay bias can also be minimized if one or two representative standards are available to adjust the initial calibration coefficients and by monitoring instrument performance with a measurement control program. To determine assay bias, multiplicity counter results can be compared against calorimetry, analytical chemistry, or other NDA instruments such as tomographic gamma-ray scanners. If the multiplicity counter measurements are to be integrated with the accountability system computer, the instrument computer hardware and software should be selected to provide a compatible software communications link. The communications link is used to transfer assay results, random and systematic errors, and measurement control data to the accountability computer.

D. Multiplicity Counter Selection Criteria

The first column of Table 8.1 summarizes the plutonium sample properties and facility operating criteria that affect the choice of multiplicity counter, conventional coincidence counter, or calorimeter for the material types to be assayed. The second column summarizes the counter design features that are needed, or that must be optimized, to meet these requirements. Table 8.1 can be used to prioritize the selection criteria, and then to prioritize the needed counter features. Then it should be possible to decide if an existing conventional coincidence counter or multiplicity counter design should be used or if a new custom design is required.

Table 8.1. Influence of sample and facility criteria on multiplicity counter selection.	
Sample and Facility Criteria	Important Multiplicity Counter Feature
Sample container size	Assay chamber size ³ He tube length Flat spatial efficiency profile
Distributed material	Flat spatial efficiency profile
Assay RSD/Count time	High detection efficiency Number of ³ He tubes
Low plutonium mass	Detectability limit calculation External shield needed
High plutonium mass	Low counter die-away time Low counting deadtime Cadmium-lined sample well Well sized to prevent double batching
High sample (α,n) rate	Low counter die-away time Flat energy spectrum efficiency
High sample moderation	Flat energy spectrum efficiency
Neutron poisons in sample	Cadmium-lined sample well Flat energy spectrum efficiency
High ²⁴¹ Am content in sample	Thick cadmium liner on sample well
Irradiated samples	Lead-lined sample well
Unsealed process materials	In-line counter design
Canned, sealed samples	Free-standing, at-line counter design
Heavy sample/end plug	Sample lifting mechanism
Low sample entry needed	Front-loading design
High room background	External shield needed
Weight/size constraint	No external shield Number of ³ He tube rings Shorter ³ He tube length
Low assay bias required	Flat spatial efficiency profile Flat energy spectrum efficiency One-two representative standards Measurement control program Validation by calorimetry, analytical chem.
Facility system integration	Software communications link

E. Commercially Available Multiplicity Equipment

Part III of this Applications Guide is a survey of existing passive neutron multiplicity counters that have already been developed for DOE facility applications. Several of these counter designs are available from commercial vendors of NDA equipment. Or, if another existing design developed at Los Alamos National Laboratory provides all of the needed design features, the design package can be made available to other DOE facilities and to commercial vendors as soon as the design concepts are fully tested and proven.

The technology required to fabricate and test neutron multiplicity counters has already been transferred from Los Alamos to several U.S. companies that manufacture NDA equipment. Important components of the transferred technology include the following: electronics junction box design, Amptek integrated preamp/discriminators, shift-register-based multiplicity electronics package, ³He tube placement and moderator design, and data analysis algorithms. The Windows NCC software package described in Part VI has also been provided to DOE facilities and to U.S. vendors.

At this point in time, there are three U.S. vendors that can supply neutron multiplicity counters and/or multiplicity electronics packages:

Canberra Industries, Inc.
800 Research Parkway
Meriden, CT 06450
203-639-2256

Antech Corporation
Unit 3, Thames Park
Lester Way, Wallingford
Oxfordshire OX10 9TB, UK
US: 303-430-8184

BNFL Instruments, Inc.
278 DP Road
Los Alamos, NM 87544
505-662-4377

F. Los Alamos Support Options

If an existing multiplicity counter design does not provide all of the needed features, a new design is required. The Los Alamos Safeguards Science and Technology Group can advise on the suitability of existing multiplicity counters for specific applications and can assist with the procurement of custom multiplicity counters. The existing commercial vendors can carry out some design modifications and can prepare new electrical and mechanical blueprint packages as needed. If substantial changes from existing designs are required, involvement of the Los Alamos design team is advisable to ensure that the desired performance will be achieved.

Support from Los Alamos can cover a range of options. The design team can carry out Monte Carlo calculations to prepare the design specifications and estimate the expected performance characteristics. The team can also provide a complete design package, construct a prototype counter, and measure representative process materials to validate the expected performance. Or, Los Alamos can participate in the process of data analysis algorithm development, acceptance testing, software integration, and documentation. Future versions of the new counter can then be obtained through commercial vendors.

Members of the Los Alamos Safeguards Science and Technology Group (NIS-5) knowledgeable about multiplicity counting include the following:

Diana Langner, 505-667-2874, dlangner@lanl.gov
Merlyn Krick, 505-667-2446, mkrick@lanl.gov
Howard Menlove, 505-667-2182, hmenlove@lanl.gov

Mark Pickrell, 505-665-5098, mpickrell@lanl.gov
James Stewart, 505-667-2166, jstewart@lanl.gov
Bill Harker, 505-667-2163, bharker@lanl.gov
Norbert Ensslin, 505-667-2444, nensslin@lanl.gov

The group's mailing address is NIS-5, Mail Stop E540, Los Alamos National Laboratory, Los Alamos, NM 87545, and the FAX number is 505-665-4433.

G. Typical Procurement Costs

Neutron multiplicity counter procurement costs vary greatly depending on counter size, number of ^3He tubes, and the level of custom design effort. The cost for obtaining a counter of an existing design "off the shelf" from a commercial vendor is in the range of \$200,000 to \$500,000 depending on the size of the counter (small sample cavity up to 55-gal. drums). The cost for obtaining a new counter that requires a new design, new hardware and software, and extensive testing and documentation is in the range of \$350,000 to \$750,000. For multiplicity measurements with existing conventional coincidence counters, where it is only necessary to add a commercially available multiplicity electronics package, the cost of that package is roughly \$9000.

H. Routine Maintenance Requirements

Maintenance requirements for thermal neutron multiplicity counters based on ^3He tubes and their associated electronics are minimal. The ^3He tubes are very rugged, stable, and reliable; of the thousands of tubes currently installed throughout DOE and international facilities, there have been no reported failures. The Amptek preamp/discriminator packages are reliable, with no reported failures after installation and setup. Low voltage power supplies, HV power supplies, and the multiplicity shift register may require infrequent repair or replacement.

The most common routine maintenance activity is replacement of the desiccant capsules in the desiccant holder/indicators built into the junction boxes, as humidity gradually seeps in. The most commonly encountered problem in facility environments has been loosening of cables or connectors, causing loss of high or low voltage to the electronics, or loss of the return signal. Careful, frequent measurement control tests such as background and bias runs are strongly recommended to watch for and diagnose these problems. Last but not least, the software package used to collect and analyze data will require periodic "maintenance" to keep up with computer upgrades or changing facility reporting requirements.

Acknowledgments

Many of our colleagues at DOE facilities provided valuable comments and corrections on the initial draft. We would especially like to acknowledge Dr. Virendra Gupta (Rocky Flats), Dr. Robert McElroy (Canberra Industries), and Dr. Avigdor Gavron (Los Alamos).

References

- Abhold 98 M. Abhold, M. Baker, R. Jie, G. Eccleston, and H. O. Menlove, "Comparison of UWCC MOX Fuel Measurements to MCNP-REN Calculations," submitted to Proc. of American Nuclear Society Winter Meeting, November 1998.
- Arnone 92 G. J. Arnone, G. S. Brunson, and K. L. Coop, "A Pulse Arrival-Time Recording Module for Analyzing Neutron Multiplicities," 1992 IEEE Nuclear Science Symposium, Los Alamos National Laboratory report LA-UR-92-3460 (October 1992).
- Arnone 96 G. J. Arnone, "A New Pulse Arrival-Time Recording Module System," 1996 IEEE Nuclear Science Symposium, Los Alamos National Laboratory report LA-UR-96-3878 (1996).
- Boehnel 75 K. Boehnel, "Determination of Plutonium in Nuclear Fuels Using the Neutron Coincidence Method," KFK2203, Karlsruhe, 1975, and AWRE Translation 70 (54/4252), Aldermaston, 1978.
- Boehnel 85 K. Boehnel, "The Effect of Multiplication on the Quantitative Determination of Spontaneously Fissioning Isotopes by Neutron Correlation Analysis," Nuclear Science and Engineering 90, 75-82 (1985).
- Boldeman 85 J. W. Boldeman and M. G. Hines, "Prompt Neutron Emission Probabilities Following Spontaneous and Thermal Neutron Fission," Nuclear Science and Engineering 91, 114 (1985).
- Bondar L. Bondar, "Time Correlation Analyzer for Nondestructive Plutonium Assay," no publication information available.
- Bondar 96 L. Bondar, "Passive Neutron Assay of Plutonium by Multiplicity Counter Technique (Theory and Practice)," Joint Research Centre, Ispra Report EUR 16462 EN, 1996.
- Bourret 94 S. C. Bourret and M. S. Krick, "A Deadtime Reduction Circuit for Thermal Neutron Coincidence Counters with Amptek Preamplifiers," Proc. INMM Annual Meeting, July 1994.
- Briesmeister 93 J. F. Briesmeister, Ed., "MCNP - A General Purpose Monte Carlo Code for Neutron and Photon Transport," Los Alamos National Laboratory report LA-12625-M, Ver. 4A (November 1993).
- Brunson 97 G. S. Brunson and G. J. Arnone, "Applications of a Versatile New Instrument Module," Los Alamos National Laboratory report LA-13271-MS (May 1997).

- Carrillo 98 L. Carrillo, N. Ensslin, M. S. Krick, D. G. Langner, and C. R. Rudy, "An Uncertainty Analysis for Determination of Plutonium Mass by Neutron Multiplicity Counting," Los Alamos National Laboratory report LA-UR-98-3044, Proc. 39th Annual INMM Meeting, July 26-30, 1998, Naples, Florida.
- Cifarelli 86 D. M. Cifarelli and W. Hage, "Models for a Three Parameter Analysis of Neutron Signal Correlation Measurements for Fissile Material Assay," *Nucl. Instr. Meth.* A251, 550 (1986).
- Crane 91 T. W. Crane and M. P. Baker, Chapter 13, "Neutron Detectors," in Passive Nondestructive Assay of Nuclear Materials, edited by T. D. Reilly, N. Ensslin, and H. A. Smith, US Nuclear Regulatory Commission NUREG/CR-5550, March 1991.
- Dierckx 83 Dierckx and Hage, *Nuclear Science and Engineering* 85, 1983.
- Dytlewski 90 N. Dytlewski, N. Ensslin, and J. W. Boldeman, "A Neutron Multiplicity Counter for Plutonium Assay," *Nuclear Science and Engineering* 104, 301-313 (1990).
- Dytlewski 91 N. Dytlewski, "Dead-time Corrections for Multiplicity Counters," *Nucl. Instr. Meth.* A305, 492-494 (1991).
- Dytlewski 93 N. Dytlewski, M. S. Krick, and N. Ensslin, "Measurement Variances in Thermal Neutron Coincidence Counting," *Nucl. Instr. Meth.* A327, 469-479 (1993).
- Ensslin 82 N. Ensslin, T. L. Atwell, D. M. Leet, B. Erkkila, R. S. Marshall, A. Morgan, C. Shonrock, B. Tippens, T. Van Lyssel, "Fast Neutron Coincidence Counter Manual," LA-8858-M (March 1982).
- Ensslin 85 N. Ensslin, "A Simple Self-Multiplication Correction for In-Plant Use," Proc. 7th ESARDA Symposium on Safeguards and Nuclear Material Management, Liege, Belgium May 1985.
- Ensslin 89 N. Ensslin, "Development of Neutron Multiplicity Counters for Safeguards Assay," INMM Meeting, Orlando, FL July 1989 LA-UR-89-2066.
- Ensslin 90a N. Ensslin, M. S. Krick, and N. Dytlewski, "Assay Variance as a Figure-of-Merit for Neutron Multiplicity Counting," *Nuclear Instruments and Methods*, A290 (1990) 197-207.
- Ensslin 90b N. Ensslin, D. G. Langner, H. O. Menlove, M. C. Miller, and P. A. Russo, "Some Target Assay Uncertainties for Passive Neutron Coincidence Counting," 31st Annual INMM Proc., Los Angeles, July 15-18, 1990, LA-UR-90-2355.
- Ensslin 91a N. Ensslin, Chapter 11, "Neutron Origins," in Passive Nondestructive Assay of Nuclear Materials, edited by T. D. Reilly, N. Ensslin, and H. A. Smith, US Nuclear Regulatory Commission NUREG/CR-5550, March 1991.
- Ensslin 91b N. Ensslin, Chapter 16, "Principles of Neutron Coincidence Counting," in Passive Nondestructive Assay of Nuclear Materials, edited by T. D. Reilly, N. Ensslin, and H. A. Smith, US Nuclear Regulatory Commission NUREG/CR-5550, March 1991.

- Ensslin 91c N. Ensslin, M. S. Krick, D. G. Langner, and M. C. Miller, "Active Neutron Multiplicity Counting of Uranium," Proc. INMM Meeting, July 1991, New Orleans.
- Ensslin 92a N. Ensslin, M. S. Krick, D. G. Langner, and M. C. Miller, "Active Neutron Multiplicity Counting of Bulk Uranium," Nucl. Mater. Manage. XX (Proc. Issue), 433-437 (1992).
- Ensslin 92b N. Ensslin, M. S. Krick, D. G. Langner, D. W. Miller, and M. C. Miller, "Measurement of the Assay Precision of the Active Neutron Multiplicity Technique," Proc. INMM Meeting, July 1992, Orlando, FL, LA-UR-92-2359.
- Ensslin 93 N. Ensslin, M. S. Krick, W. C. Harker, M. C. Miller, R. D. McElroy, P. A. McClay, W. L. Belew, R. N. Ceo, L. L. Collins, and P. K. May, "Analysis of Initial In-Plant Active Neutron Multiplicity Measurements," LA-UR-93-2631, INMM Meeting Proc., July 1993.
- Ensslin 95 N. Ensslin, M. S. Krick, and H. O. Menlove, "Expected Precision of Neutron Multiplicity Measurements for Waste Drums," LA-UR-95-452, INMM Meeting Proc., July 1995.
- Ensslin 96 N. Ensslin, M. E. Abhold, and H. A. Smith, "Results from the First Waste and Residue NDA Measurements School," LA-UR-96-361, Proc. INMM Annual Meeting, July 1996.
- Ensslin 97 N. Ensslin, A. Gavron, W. Harker, M. S. Krick, D. G. Langner, M. C. Miller, and M. M. Pickrell, "Expected Precision for Neutron Multiplicity Assay Using Higher Order Moments," LA-UR-97-2716, Proc. INMM Annual Meeting, July 1997.
- Ensslin 98 N. Ensslin, L. A. Foster, W. C. Harker, M. S. Krick, and D. G. Langner, "Inventory Verification Measurements Using Neutron Multiplicity Counting," Los Alamos National Laboratory report LA-UR-98-2940, Proc. 39th Annual INMM Meeting, July 26-30, 1998, Naples, Florida.
- Gavron 74 A. Gavron and Z. Fraenkel, "Neutron Correlations in Spontaneous Fission of ²⁵²Cf," Physical Review C9, 623 (1974).
- Hage 85 W. Hage and D. M. Cifarrelli, "Correlation Analysis with Neutron Count Distributions in Randomly or Signal Triggered Time Intervals for Assay of Special Nuclear Materials," Nuclear Instruments and Methods A236, 165 (1985).
- Halbig 91 J. K. Halbig, S. C. Bourret, P. R. Collinsworth, W. J. Hansen, and M. S. Krick, "Recent Developments in Multiplicity Counting Hardware at Los Alamos," Conference Record of the 1991 IEEE Nuclear Science Symposium and Medical Imaging Conference, Vol. 2, pp. 1261-1265 (1991).
- Halbig 94 J. K. Halbig, S. C. Bourret, W. J. Hansen, D. V. Hicks, S. F. Klosterbuer, and M. S. Krick, "Portable Shift Register," Proc. INMM Annual Meeting, July 1994.
- Harker 96 W. C. Harker and M. S. Krick, "Software Users Manual Windows NCC," Version 1.24, Los Alamos National Laboratory report, Copyright 1997 by the Regents of the University of California, September 1996.

- Holden N. E. Holden and M. S. Zucker, "Neutron Multiplicities for the Transplutonium Nuclides," Brookhaven National Laboratory report (unpublished).
- Krick 84 M. S. Krick and J. E. Swansen, "Neutron Multiplicity and Multiplication Measurements," Nucl. Instr. Meth. 219, 38, 393 (1984).
- Krick 92a Application Note on Passive Neutron Coincidence Counters (December 1992).
- Krick 92b M. S. Krick, D. G. Langner, D. W. Miller, J. R. Wachter, and S. S. Hildner, "Thermal Neutron Multiplicity Counter Measurements," Los Alamos National Laboratory report LA-UR-92-2362, Proc. INMM 33rd Annual Meeting, Orlando, FL, July 1992.
- Krick 93 M. S. Krick and W. C. Harker, "Multiplicity Neutron Coincidence Counting User's Manual," Los Alamos National Laboratory report LA-UR-93-1394 (April 1993).
- Krick 94a M. S. Krick, N. Ensslin, D. G. Langner, M. C. Miller, R. N. Ceo, P. K. May, and L. L. Collins, Jr., "Active Neutron Multiplicity Analysis and Monte Carlo Calculations," LA-UR-94-2440, INMM Meeting Proc., July 1994.
- Krick 94b Application Note on the Passive Neutron Multiplicity Counter (June 1994).
- Krick 96 M. S. Krick, N. Ensslin, R. N. Ceo, and P. K. May, "Analysis of Active Neutron Multiplicity Data for Y-12 Skull Oxide Samples," LA-UR-96-343, Proc. INMM Annual Meeting, July 1996.
- Krick 97a M. S. Krick, "Thermal Neutron Multiplicity Counting of Samples with Very Low Fission Rates," LA-UR-97-2649, Proc. INMM Annual Meeting, July 1997.
- Krick 97b M. S. Krick, D. G. Langner, and J. E. Stewart, "Energy-Dependent Bias in Plutonium Verification Measurements Using Thermal Neutron Multiplicity Counters," Los Alamos National Laboratory report LA-UR-97-3427, presented at the IAEA Symposium on International Safeguards, Vienna, Austria, October 13-17, 1997.
- Krick 98 M. S. Krick, W. C. Harker, P. M. Rinard, T. R. Wenz, W. Lewis, P. Pham, and P. De Ridder, "The IAEA Neutron Coincidence Counting (INCC) and the DEMING Least-Square Fitting Programs," Los Alamos National Laboratory report LA-UR-98-2378, Proc. 39th Annual INMM Meeting, July 26-30, 1998, Naples, Florida.
- Langner 90 D. G. Langner, N. Ensslin, and M. S. Krick, "Pyrochemical Neutron Multiplicity Counter Design," 31st Annual INMM Proc., Los Angeles, July 15-18, 1990, LA-UR-90-2255.
- Langner 91a D. G. Langner, N. Dytlewski, and M. S. Krick, "Pyrochemical Multiplicity Counter Development," 32nd Annual INMM Proc., July 1991.
- Langner 91b D. G. Langner, M. S. Krick, N. Ensslin, G. E. Bosler, and N. Dytlewski, "Neutron Multiplicity Counter Development," LA-UR-91-1569, ESARDA Meeting, Avignon, France, May 14-16, 1991.

- Langner 92 D. G. Langner, M. S. Krick, and D. W. Miller, "The Use of Ring Ratios to Detect Sample Differences in Passive Neutron Counting," Nucl. Matls. Management (Proc. Issue) XXI, 790-797 (1992).
- Langner 93a D. G. Langner and P. A. Russo, "Geometry-Based Multiplication Correction for Passive Neutron Coincidence Assay of Materials with Variable and Unknown (α,n) Neutron Rates," Los Alamos National Laboratory report LA-12504-MS (February 1993).
- Langner 93b D. G. Langner, M. S. Krick, D. R. Parks, and K. S. Hooper, "Thermal Neutron Multiplicity Measurements Using the Pyrochemical Multiplicity Counter at Lawrence Livermore National Laboratory," INMM Meeting, Scottsdale, Ariz., July 18-21, 1993 (LA-UR-93-2610).
- Langner 94 D. G. Langner, M. S. Krick, and K. E. Kroncke, "A Large Multiplicity Counter for the Measurement of Bulk Plutonium," LA-UR-94-2313, Nucl. Matls. Management (Proc. Issue) XXIII 474-479 (1994).
- Langner 95 D. G. Langner, M. S. Krick, and K. E. Kroncke, "The Application of Neutron Multiplicity Counting to the Assay of Bulk Plutonium Bearing Materials at RFETS and LLNL," Los Alamos National Laboratory report LA-UR-95-3320, American Nuclear Society Fifth International Conference on Facility Operations-Safeguards Interface, Jackson Hole, Wyoming, Sept. 1995.
- Langner 96a D. G. Langner, N. Ensslin, M. S. Krick, H. O. Menlove, M. C. Miller, and J. E. Stewart, "Advances in Nondestructive Assay Using Neutron Coincidence Counting Techniques," LA-UR-95-4131, American Chemical Society Annual Meeting, New Orleans, LA., March 24-28, 1996.
- Langner 96b D. G. Langner, J. B. Franco, J. G. Fleissner, V. Fotin, J. Xiao, and R. Lemaire, "The Performance of the 30-Gallon Drum Neutron Multiplicity Counter at the Rocky Flats Environmental Technology Site," Los Alamos National Laboratory report LA-UR-96-2569.
- Langner 97a D. G. Langner, M. S. Krick, J. E. Stewart, and N. Ensslin, "The State-of-the-Art of Thermal Neutron Multiplicity Counting," LA-UR-97-2734, Proc. INMM Annual Meeting, July 1997.
- Langner 97b D. G. Langner, J. B. Franco, R. K. Larsen, V. Fotin, R. Lemaire, P. Pham, J. Xiao, T. Moriarty, and B. Heaysman, "Assay of Impure Plutonium Oxide with the Large Neutron Multiplicity Counter for IAEA Verification of Excess Weapons Material at the Rocky Flats Environmental Technology Site," Los Alamos National Laboratory report LA-UR-97-2650, Proc. INMM Annual Meeting, July 1997.
- Langner 97c D. G. Langner, M. R. Sweet, S. D. Salazar, and K. E. Kroncke, "FB-Line Neutron Multiplicity Counter Operation Manual," Los Alamos National Laboratory report LA-13395-M, October 1997.

- Langner 98 D. G. Langner, M. R. Sweet, S. D. Salazar, and K. E. Kroncke, "A New Neutron Multiplicity Counter for the Measurement of Impure Plutonium Metal at the Westinghouse Savannah River Site," Los Alamos National Laboratory report LA-UR-98-2890, Proc. 39th Annual INMM Meeting, July 26-30, 1998, Naples, Florida.
- McElroy 97 R. McElroy, "Characterization of the PRMC Unit 1 for Multiplicity Counting," Canberra Industries report CI-54852, June 1997.
- Menlove 85 H. O. Menlove and J. E. Swansen, "A High-Performance Neutron Time Correlation Counter," Nuclear Technology **71** 497-505, (November 1985).
- Menlove 89 H. O. Menlove, R. Abedin-Zadeh, R. Zhu, "The Analysis of Neutron Coincidence Data to Verify Both Spontaneous Fission and Fissionable Isotopes," Los Alamos National Laboratory report LA-11639-MS (August 1989).
- Menlove 93 H. O. Menlove, J. Baca, M. S. Krick, K. E. Kroncke, and D. G. Langner, "Plutonium Scrap Multiplicity Counter Operation Manual," Los Alamos National Laboratory report LA-12479-M (ISPO-349) (January 1993).
- Menlove 96 H. O. Menlove, D. H. Beddingfield, M. M. Pickrell, D. R. Davidson, R. D. McElroy, and D. B. Brochu, "The Design of a High Efficiency Neutron Counter For Waste Drums to Provide Optimized Sensitivity for Plutonium Assay," Los Alamos National Laboratory report LA-UR-96-4585, 5th Nondestructive Assay and Nondestructive Examination Waste Characterization Conference, Salt Lake City, Utah, January 14-16, 1997.
- Miller 96 M. C. Miller, R. C. Byrd, N. Ensslin, W. C. Feldman, M. S. Krick, T. H. Prettyman, and P. A. Russo, "Conceptual Design of a Fast Neutron Coincidence Counter for Verification of Special Nuclear Materials," LA-UR-96-1171, Third Topical Meeting on Industrial Radiation and Radioisotope Measurements and Applications, Raleigh, N. C. 27605, October 6-9, 1996.
- Miller 97 M. C. Miller, R. C. Byrd, N. Ensslin, M. S. Krick, D. Mayo, D. J. Mercer, T. H. Prettyman, and P. A. Russo, "A Fast Neutron Detection System for Verification of Special Nuclear Material," LA-UR-97-2806, Proc. INMM Annual Meeting, July 1997.
- Pickrell 96 M. M. Pickrell, "Development of a High-Efficiency Neutron Detector Using Novel Materials," LA-UR-96-4821, 5th Nondestructive Assay and Nondestructive Examination Waste Characterization Conference, Salt Lake City, Utah, January 14-16, 1997.
- Pickrell 97a M. M. Pickrell and N. Ensslin, "Application of Neutron Multiplicity Counting to Waste Assay," LA-UR-97-545, 5th Nondestructive Assay and Nondestructive Examination Waste Characterization Conference, Salt Lake City, Utah, January 14-16, 1997.

- Pickrell 97b M. M. Pickrell, N. Ensslin, A. Gavron, and H. O. Menlove, "Extensions of Neutron Multiplicity Counting to Waste and Low-Level Assay," LA-UR-97-3532, IAEA Symposium on International Safeguards, Vienna, Austria, October 13-17, 1997.
- Rinard 97 P. M. Rinard, M. S. Krick, T. A. Kelley, C. M. Schneider, G. A. Sheppard, W. C. Harker, P. A. McClay, R. W. Saylor, S. R. Beck-Montgomery, W. F. Harlow, and H. W. Blizzard, "Measurements on an Inventory of Mixed Fissile Materials in Shipping Containers," Los Alamos National Laboratory report LA-13356-MS, Sept. 1997.
- Robba 83 A. Robba, E. Dowdy, and H. Atwater, "Neutron Multiplicity Measurements Using Moments of the Neutron Counting Distribution," Nuclear Instruments and Methods 215, 473 (1983).
- Sampson 93 T. E. Sampson, T. L. Cremers, J. C. Martz, and W. R. Dvorzak, "An NDA System for Automated, In-Line Weapons Component Dismantlement," Proc. INMM Meeting, Scottsdale, Ariz., July 18-21, 1993.
- Smith 91 H. A. Smith and N. Ensslin, Chapter 23, "NDA Applications Guide," in Passive Nondestructive Assay of Nuclear Materials, edited by T. D. Reilly, N. Ensslin, and H. A. Smith, US Nuclear Regulatory Commission NUREG/CR-5550, March 1991.
- Stewart 86 J. E. Stewart, "A Hybrid Monte Carlo/Analytical Model of Neutron Coincidence Counting," Proc. American Nuclear Society Winter Meeting, Nov. 16-20, 1986, Volume 53, p. 149.
- Stewart 89 J. E. Stewart, R. R. Ferran, and M. S. Krick, "Measurement Performance Optimization for Thermal Neutron Multiplicity Counters," Safeguards and Security Progress Report, January-December 1989, LA-11914-PR, pp. 24-27.
- Stewart 91a J. E. Stewart, et. al., "A Versatile Passive/Active Neutron Coincidence Counter for In-Plant Measurements of Plutonium and Uranium," in Proceedings of the 13th ESARDA Symposium on Safeguards and Nuclear Material Management, Avignon, France, 14-16 May 1991 (pp. 317-323).
- Stewart 91b J. E. Stewart, Chapter 14, "Principles of Total Neutron Counting," in Passive Nondestructive Assay of Nuclear Materials, edited by T. D. Reilly, N. Ensslin, and H. A. Smith, US Nuclear Regulatory Commission NUREG/CR-5550, March 1991.
- Stewart 93 Application Note on the Passive/Active Neutron Coincidence Counter (April 1993).
- Stewart 95 J. E. Stewart, M. S. Krick, D. G. Langner, and T. D. Reilly, W. Theis, R. J. Lemaire, and J. Xiao, "Implementation of Neutron Counting Techniques at US Facilities for IAEA Verification of Excess Materials from Nuclear Weapons Production," Los Alamos National Laboratory report LA-UR-95-2329, Proc. INMM 36th Annual Meeting, Palm Desert, CA, July 1995.

- Stewart 96a J. E. Stewart, M. S. Krick, J. Xiao, R. J. Lemaire, V. Fotin, L. McRae, D. Scott, and G. Westsik, "Assay of Scrap Plutonium Oxide by Thermal Neutron Multiplicity Counting for IAEA Verification of Excess Materials from Nuclear Weapons Production," Los Alamos National Laboratory report LA-UR-96-2515, Proc. INMM 37th Annual Meeting, Naples, FL, July 1996.
- Stewart 96b J. E. Stewart, S. C. Bourret, N. Ensslin, M. S. Krick, W. J. Hansen, and W. C. Harker, "A Two-Fold Reduction in Measurement Time for Neutron Assay: Initial Tests of a Prototype Dual-Gated Shift-register (DGSR)," LA-UR-96-345, INMM Meeting Proc., July 1996.
- Stewart 97 J. E. Stewart, M. S. Krick, J. Xiao, R. J. Lemaire, and V. Fotin, "Performance of the Plutonium Scrap Multiplicity Counter for Verification of Excess Scrap Plutonium Oxide from Nuclear Weapons Production," Los Alamos National Laboratory report LA-UR-97-2070, ISPO No. 393.
- Stewart 98 J. E. Stewart, M. S. Krick, D. G. Langner, and T. R. Wenz, "Neutron Multiplicity Assay of Impure Materials Using Four Different Neutron Counters," Los Alamos National Laboratory report LA-UR-98-2597, Proc. 39th Annual INMM Meeting, July 26-30, 1998, Naples, Florida.
- Terrell 57 J. Terrell, "Distribution of Fission Neutron Numbers," Physical Review 108, 783 (1957).
- Wachter 87 J. R. Wachter, E. L. Adams, and N. Ensslin, "Prototype Fast Neutron Counter for the Assay of Impure Plutonium," INMM/ANS Conference on the Safeguards / Facility Process Interface, San Diego, Nov. 1987.
- Zucker 84 M. S. Zucker and N. Holden, "Parameters for Several Plutonium Nuclides and ²⁵²Cf of Safeguards Interest," Proc. Sixth Annual Symp. ESARDA, Venice, 1984, p. 341.
- Zucker 86 M. S. Zucker and N. Holden, "Energy Dependence of the Neutron Multiplicity P_V in Fast Neutron Induced Fission of ^{235,238}U and ²³⁹Pu," IAEA Conference on Nuclear Safeguards Technology, Vienna, November 1986, Vol. 2, p. 329.

This report has been reproduced directly from the best available copy.

It is available to DOE and DOE contractors from the Office of Scientific and Technical Information, P.O. Box 62, Oak Ridge, TN 37831. Prices are available from (615) 576-8401.

It is available to the public from the National Technical Information Service, US Department of Commerce, 5285 Port Royal Rd. Springfield, VA 22616.

Los Alamos
NATIONAL LABORATORY

Los Alamos, New Mexico 87545